

GARO Entity Pro installation and operation

Version 1.3



CONTENTS

1	Introduction	5
1.1	Document description	5
1.2	Product description	5
1.2.1	Feature description	5
1.2.2	Definitions	5
1.3	Intended use	6
1.4	Contact	6
2	Safety	9
2.1	Safety definitions	9
2.2	Safety instructions for installation	9
3	Product overview	11
3.1	Charging station system overview	11
3.2	Charging station packaging overview	12
3.3	Product variants	13
3.4	Charging station overview	15
3.5	Dimensions	16
3.5.1	Single version installation bracket (IB)	16
3.5.2	Double version installation bracket (IB)	17
4	Installation	19
4.1	To do before installation	19
4.2	Personnel requirements	19
4.3	Personal protective equipment	19
4.4	To do a plan for the installation	20
4.5	To generate the installation code	21
4.6	To do a check of the delivery	21
4.7	To ensure the necessary tools	21
4.8	To ensure the necessary installation material	22
4.9	To decide internet connection type	23
4.10	To connect several charging stations	23
4.10.1	Before setup	23
4.10.2	Simple setup scenarios	24
4.10.3	Connection group hierarchy	24
4.11	To decide the position of the charging station	26
4.12	Cable installation	26
4.12.1	To install the stickers for IT 230 V	27
4.12.2	To prepare the installation bracket for the cable installation	27
4.12.3	To install the installation bracket to a wall	28
4.12.4	To prepare the power cable for installation	29
4.12.5	To connect the power cable to the terminal	31
4.12.6	To install a second power cable (daisy-chaining method)	33
4.12.7	To prepare the installation bracket with an ethernet cable	33
4.12.8	To prepare the installation bracket with a second ethernet cable	34
4.12.9	To connect the charging station to the Internet with communication modem (Cat-M1/NB/GPRS)	35
4.12.10	To install the control cable to the installation bracket	35
4.12.11	To change the position of the type 2 outlet or fixed cable	36
4.12.12	To do a test of the power connection	37
4.12.13	To install a protection cover	39

4.12.14	To attach the charging unit to the installation bracket	39
4.12.15	To do a final functionality test of the product	41
4.12.16	To mount the front cover of the charging unit.....	43
4.13	Dynamic Load Management (DLM)	43
4.13.1	Dynamic Load Management (DLM) functionality	43
4.13.2	Load interface installation overview	46
4.13.3	To install the load interface in an electrical cabinet	50
4.14	GARO Connect.....	56
4.14.1	The GARO Connect app	56
4.14.2	GARO Connect app process overview.....	57
4.14.3	GARO Connect app symbols overview	58
4.14.4	Owner.....	61
4.14.5	Installer.....	68
5	Operation	85
5.1	To charge an electrical vehicle	85
5.1.1	Indication light.....	86
5.2	To schedule charging	87
5.3	To stop the charging of the electrical vehicle	87
6	Maintenance.....	89
6.1	To clean the charging station	89
6.2	To do a visual check of the charging station	89
6.3	To do a factory reset.....	89
6.4	To do an earth fault test	89
6.5	To do a reset after a minor ground fault.....	90
6.6	To do a reset of a tripped circuit breaker	90
6.7	To replace a charging unit	91
6.8	PME - Protective Multiple Eathing (UK versions only)	92
6.9	Service	92
6.10	Repair	92
7	Troubleshooting	93
7.1	Troubleshooting	93
8	Technical data	95
8.1	Charging station technical data	95
8.2	Load interface technical data	97
8.3	Accessories	98
	Source code.....	99
	EU Declaration of conformity	101

1 INTRODUCTION

1.1 DOCUMENT DESCRIPTION

This document describes installation and use of the Entity Pro product, which is a member of the Entity family. Also, the Entity Balance Load Interface installation is described.

1.2 PRODUCT DESCRIPTION

This product is a GARO charging station for electrical vehicles.

1.2.1 FEATURE DESCRIPTION

Entity is a series of charging stations and load interfaces that can operate together. They are based on the versatile open protocol OCPP, that also makes it possible to integrate them in other systems as well as to include third party OCPP based charging stations in the same systems. Entity Pro is a wallbox that is easy to use, install, and enables advanced functionality.

Configuration and operation are supported by the GARO Connect app, available for android and Apple devices.

1.2.2 DEFINITIONS

In the installation, setup and operation of the Entity Pro charging stations, there are several terms and expressions that is important to understand. Read about the most common terms and expressions below.

Charger group: A charger group contains several charging stations at the same location. The charger group manages the access rights to the charging stations within the charger group.

Charging station: A charging station is used for charging EVs. The charging station is connected to a location and an owner. The charging station can be installed and monitored through the GARO Connect app and be part of a charger group.

Connection group: A group of charging station(s) and other devices that shares the same resource, such as a fuse. The connection group is set up to protect fuses from overload and is controlled by one device (either a charging station or a load interface) to act as a master device. Normally, the Connection group also defines how the internet is connected to the units, through a master. For more information about connection groups, refer to [4.13.1 Dynamic Load Management \(DLM\) functionality, page 43](#).

DLM system: DLM stands for Dynamic Load Management and is a software-based solution that is meant to manage the loads of the system of several charging stations in an installation. DLM can be defined as the current limiting logic applied to a connection group.

EV: Electrical vehicle.

EV driver: An EV driver is a person that has access to the charging station(s). The EV driver can be part of an EV driver group and gain access to the charging station (s) with an RFID tag or an app. The EV driver can use the GARO Connect app to monitor charging of an EV.

EV driver group: An EV driver group is a group of EV drivers with the same access rights within the organization. The access rights are managed on an organizational level, which means that the EV driver group can be used at several locations within the organization.

GARO Connect app: The application from which it is possible to install, manage and operate Entity charging stations. For more information about the GARO Connect application, refer to [4.14 GARO Connect, page 56](#).

Installer: An installer is a certified installer or acts on behalf of a certified installer. The installer is hired by the owner to do the electrical steps of the installation of the charging station(s) and/or a load interface. The installer can see and change settings of the units in the location. The installer provided access to a location with the installation code, just like a key. The installer can during the first setup act as a temporary owner to assist with the installation.

Load interface: The load interface connects a current metering device to the system. This is needed when a fuse is feeding not only charging stations and needs monitored/dynamic overload protection (DLM).

For more information about load interface, refer to [4.13.1 Dynamic Load Management \(DLM\) functionality, page 43](#).

Location: A location is a physical address of where one or several charging station(s) are installed. The location is connected to an owner and can tell EV drivers where it is possible to charge EVs. The location can contain several charger groups. All charging stations within a location normally uses the same grid connection point. A location can be transferred to another owner.

Organization: An organization contains one or several locations. The organization shares the same owner(s) and it is possible to create groups of EV drivers to manage access to the charging stations.

Owner: An owner is a person who owns one or several charging stations. This person owns the location(s) and invites the installer to do the installation of the charging station(s). The owner can add other owners, manage access for EV drivers and EV driver groups, manage charger groups and create locations, organizations and EV driver groups. The owner can monitor and control status of the owned charging station(s).

PME: Protective Multiple Earthing. A mandatory safety function only applicable for the United Kingdom (UK).

Unit: A charging station or a load interface.

1.3 INTENDED USE

The product is intended for electrical vehicle charging. Do not use the product for any other tasks.

NOTE

Follow local rules and restrictions regarding the product and installation.

1.4 CONTACT

SE + non-listed countries:

GARO E-Mobility AB

Box 203

335 33 Gnosjö, Sweden

Telephone +46 370 332 00

support@garo.se

www.garo.se

FI:

GARO Finland Oy

Itälahdenkatu 18 a, FI-00210 HELSINKI, Finland

Telephone: +358 20 752 9030

E-mail: myynti@garo.fi

www.garo.fi

IR:

GARO Electric Ireland Ltd

19/307 Northwest Business Park, Blanchardstown, IE-DUBLIN 15, Ireland

Telephone: +35 31 882 00 30

E-mail: info@garo.ie

www.garo.ie

NO:

GARO AS

Sankt Hallvardsvei 3, NO-3414 LIERSTRANDA, Norway

Telephone: +47 32 89 64 50

E-mail: garo@garo.no

www.garo.no,

PL:

GARO Polska Sp z o.o.

Wislawy Szymborskiej 18, PL-70-784 SZCZECIN, Poland

Telephone: +48 91 881 17 70 , +48 91 424 33 35

Email: info@garo.com.pl

www.garo.com.pl

UK:

GARO Electric Ltd

Sales & Customer Service

Unit 16 Urban Express Park

Aston Hall Road

Birmingham, B6 7FH

2 SAFETY

2.1 SAFETY DEFINITIONS

WARNING



Risk of personal injury or death.

CAUTION

Risk of damage to the product or the adjacent area.

NOTE

Information that is necessary in a given situation.

2.2 SAFETY INSTRUCTIONS FOR INSTALLATION

WARNING

Read and understand the safety warnings below before installation of the product.

WARNING

Do not use a damaged charging station or a charging station that has a red blinking (slow 0,5 Hz) indication light. If a defect is found, speak to the owner of the charging station. The owner can be found in the GARO Connect app. Only use charging cables with no visible defects and intended for charging the relevant EV.

Follow all instructions for the relevant EV.

- Ventilation signal from EV is not supported. This means that test of “State D” is not possible.
 - Adapters for charging connectors are not allowed to be used.
 - Cord extension sets for charging cable is not allowed to be used.
 - Do not use private power generators as a power source for charging.
 - Incorrect installation and testing of the charging station could potentially damage either the EV and/ or the charging station itself.
 - Do not operate the charging station in temperatures outside its operating range. Refer to [8.1 Charging station technical data, page 95](#).
 - Avoid high voltage insulation testing on connected charging stations. If insulation testing is necessary, first remove the charging unit from the installation bracket.
 - If the charging station is set up without any internet connectivity, it will allow charging up to the maximum current defined for the charging unit. The maximum current can be up to 32 A. Default at delivery, the maximum setting is 16 A. This means that an unconfigured charging station will function without any internet connection, up to 16 A.
 - Do not use the product if any parts are damaged.
 - Do not connect an EV if the indication light is blinking a slowly in red (0,5 Hz).
- Do not remove the screws from the sealed assembly points on the rear side of the charging unit. Removed screws or broken sealing will void the warranty.
 - All installation must be carried out by an authorized installer and comply with local country installation regulations. If any questions, please contact your local electrical authority.
 - Refer to local standards and regulations not to exceed charging current limitations.

3 PRODUCT OVERVIEW

3.1 CHARGING STATION SYSTEM OVERVIEW

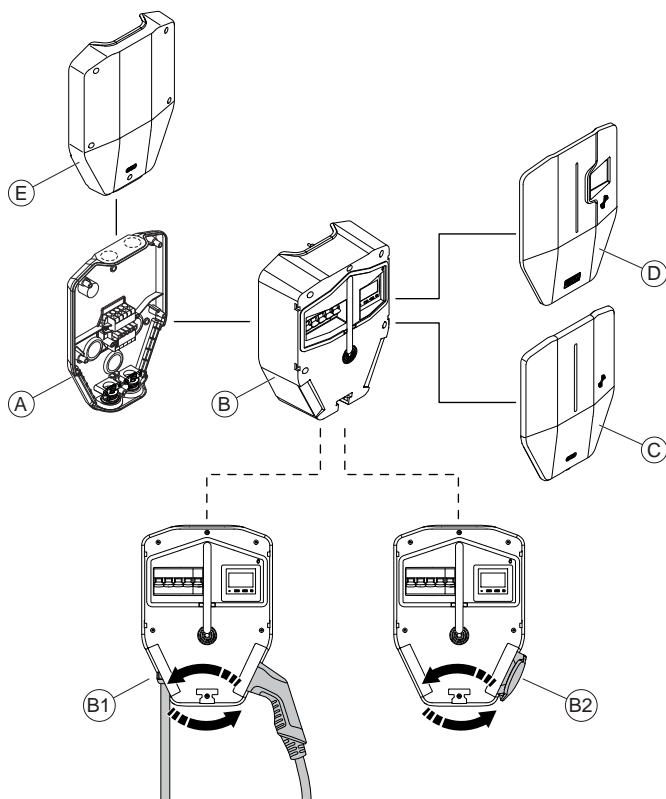

- A. Installation bracket. The installation bracket is available as single and double (side by side).
- B. Charging unit. The charging unit is available in several versions. Refer to [3.3 Product variants, page 13](#). The fixed cable (B1) or Type 2 outlet (B2) can be positioned on either side of the charging unit.
- C. Front cover for charging units without an MID certified, visible energy meter. The front cover is available in several colors.
- D. Front cover for charging units with an MID certified, visible energy meter. The front cover is available in several colors.
- E. Protection cover. The protection cover is an accessory that is used for a prepared installation without an attached charging unit.

Garö offers various installation accessories. Both as a complete charging station or as individual system components.

3.2 CHARGING STATION PACKAGING OVERVIEW

Charging Station (CS)

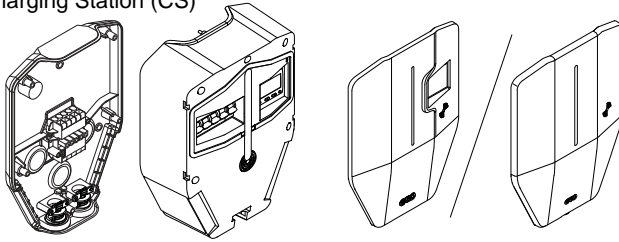

Charging Unit (CU)

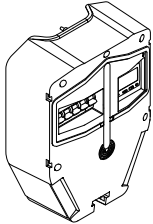

Front cover

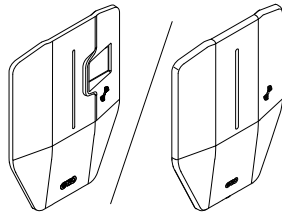

Installation bracket - single (IB)

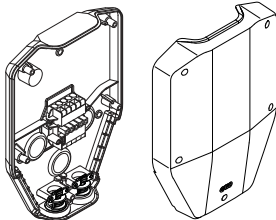

Installation bracket - double (IB)

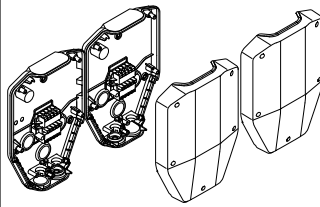

Charging station (CS)

A charging station is a complete kit, packed in a box. It contains all parts required for EV charging. The product is available in several versions.

Charging unit (CU)

The charging unit is the active part of the charging station. To be plugged into the installation bracket. The charging unit is available in several versions.

Front cover

Front cover for charging units with or without an MID certified, visible energy meter. The front cover is available in several colors.

Installation bracket – single (IB)

The installation bracket is where the physical installation is done. It contains a permanent RFID tag with the identity of the physical charging station. The installation bracket is available as single and double.

The protection cover covers the installation in the installation bracket. The protection cover is an accessory that is used for a prepared installation without an attached charging unit.

3.3 PRODUCT VARIANTS

The Entity Pro charging station (and separate charging unit) is available in several product variants.

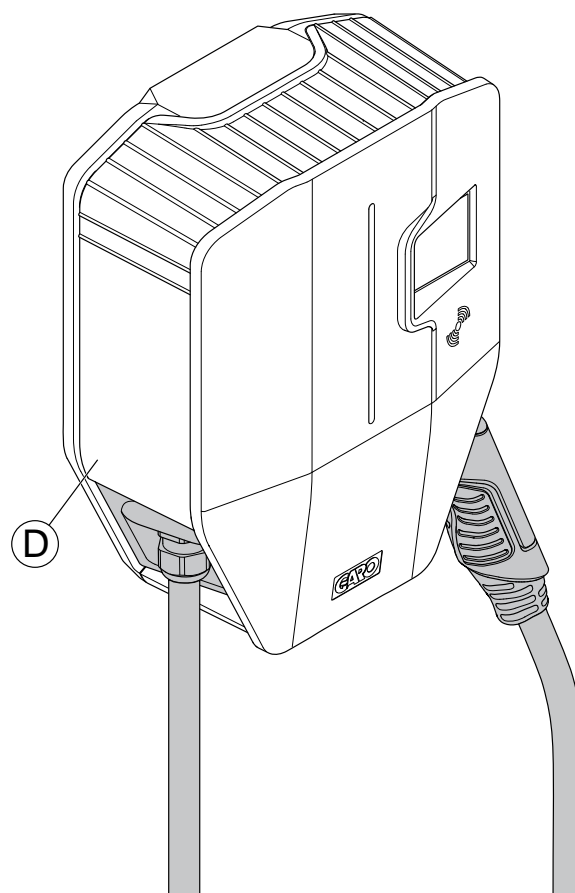
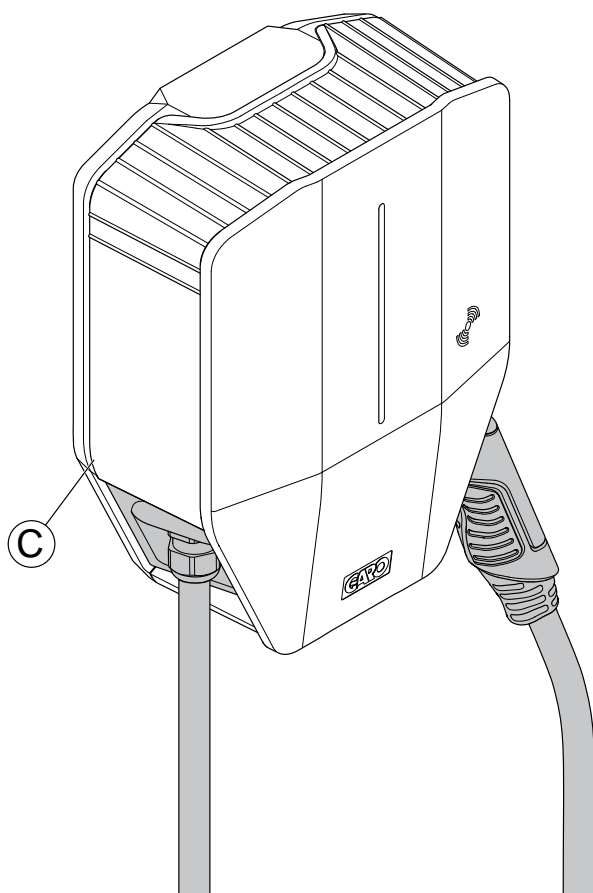
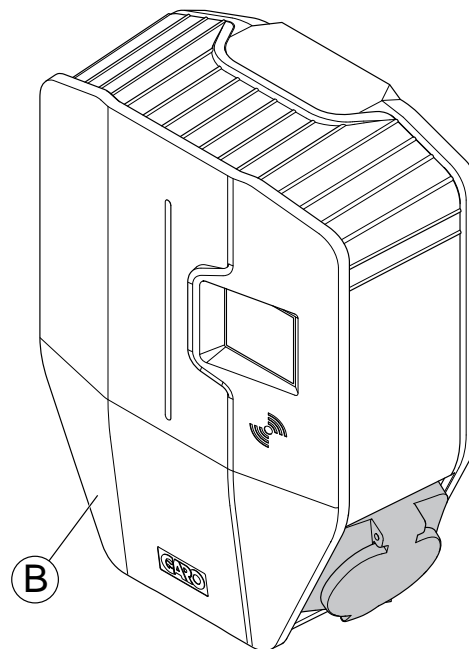
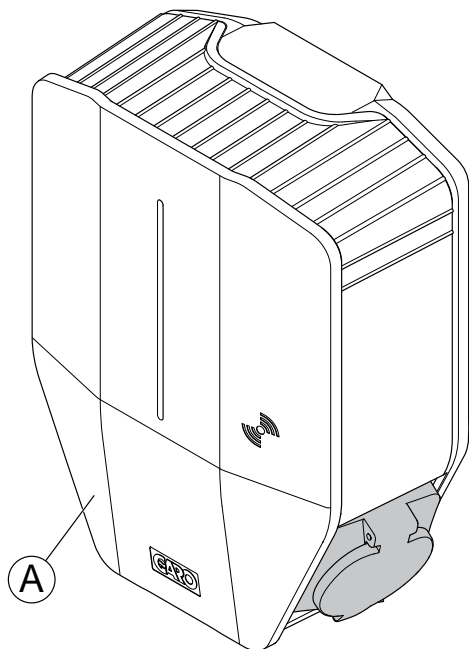

- A. With Type 2 outlet, with internal energy meter (not visible on the front cover).
- B. With Type 2 outlet, with MID certified, visible energy meter.
- C. With Type 2 cable, with internal energy meter (not visible on the front cover).
- D. With Type 2 cable, with MID certified, visible energy meter.

The product concept can for special high volume orders be customized to with or without the features listed below:

- Type 2 outlet or fixed cable.
- Long fixed cable (8 m) or normal fixed cable (5 m).
- 32 A or 20 A fixed cable.
- Three-phase or one-phase.
- With or without phase balancing.
- With or without mobile communication modem (Cat-M1/NB/GPRS).
- With or without ISO 15118 HW support.
- With or without SIM, supplied from GARO.
- With or without PME protection (UK only).

3.4 CHARGING STATION OVERVIEW

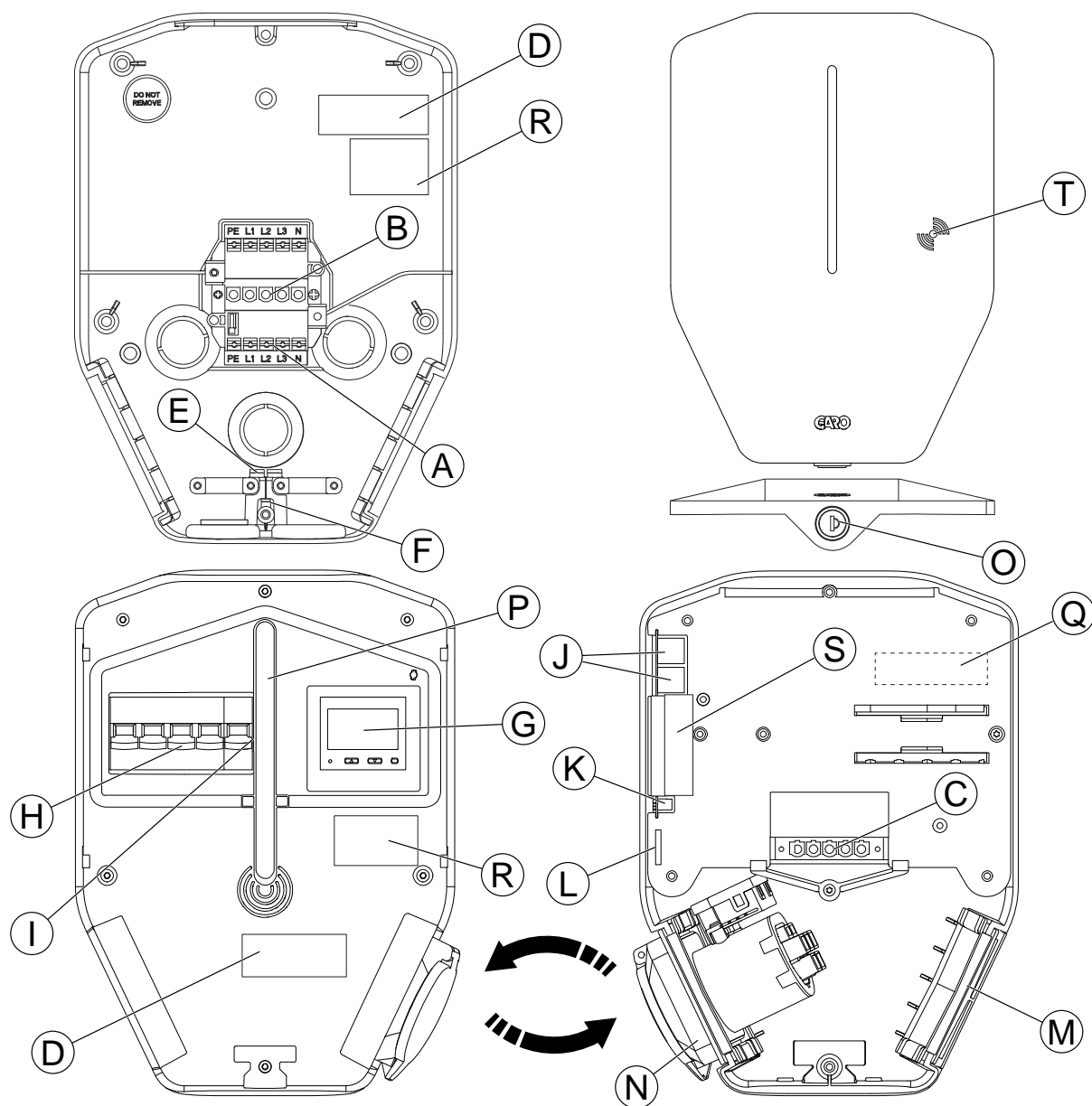

- A. Power connection terminal (in and out).
- B. Bracket terminal connector.
- C. Charging unit connector.
- D. Installation bracket QR label.
- E. Ethernet cable inlet.
- F. Control cable inlet.
- G. Visible MID energy meter (optional).
- H. All-pole circuit breaker, manual reset.
- I. PE disconnection relay (PME protection variant only) (for UK only).
- J. 2 port Ethernet switch RJ45.
- K. Control cable port and connector.
- L. SIM card slot (size 3 FF/Micro).
- M. Flat adapter cover.¹

¹ The fixed cable variant of the charging unit has the fixed cable placed here.

- N. Type 2 outlet.²
- O. Front cover lock.
- P. Indication light.
- Q. Optional ID-label placement after installation.
- R. Label, load interface type.
- S. Sealing label.
- T. RFID reader area.

3.5 DIMENSIONS

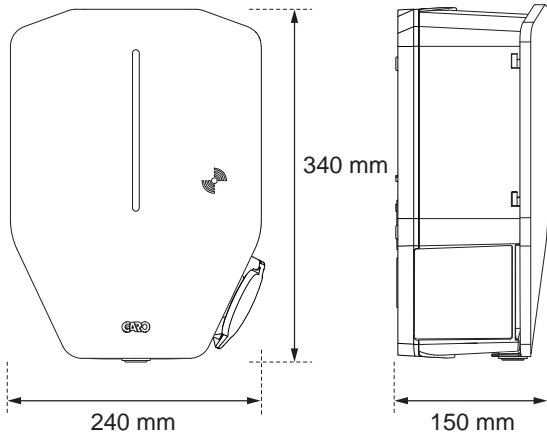
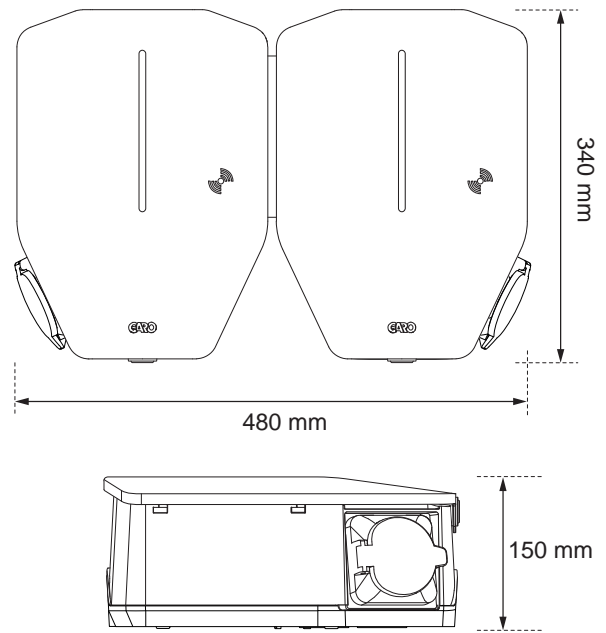

Dimensions for bracket hole positions:

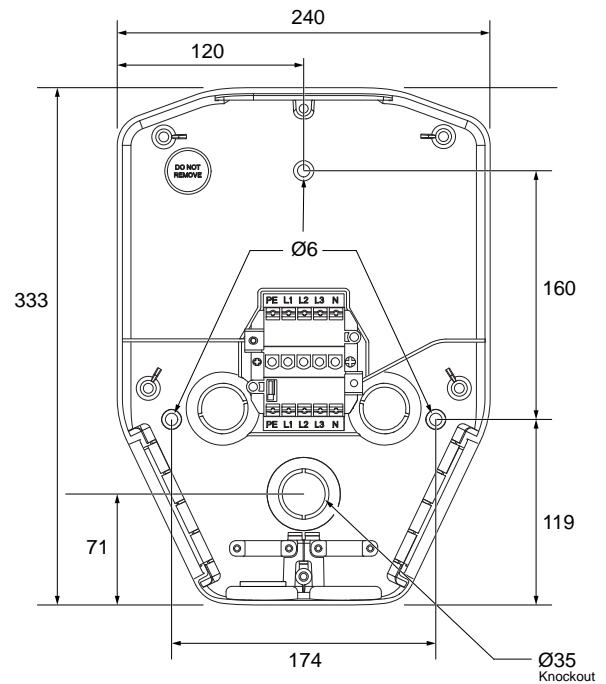

3.5.1 SINGLE VERSION INSTALLATION BRACKET (IB)

Bracket and hole dimensions:

2. The fixed cable variant of the charging unit has the cable parking placed here.

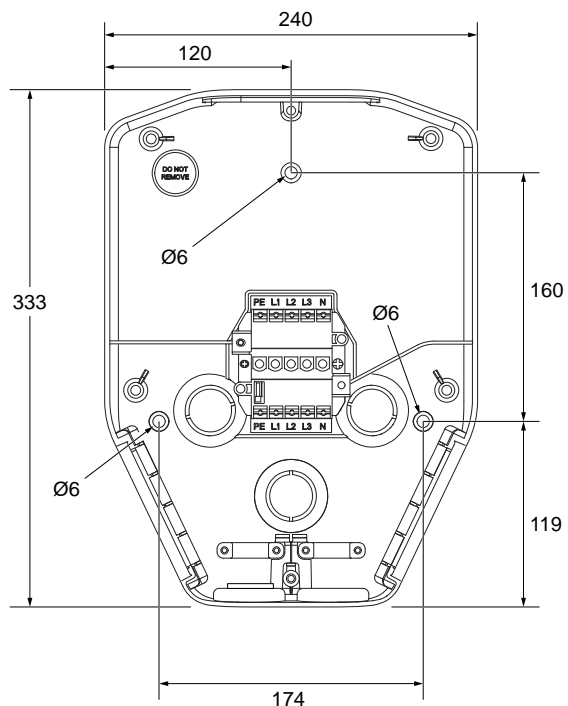

Bracket and knockout dimensions:

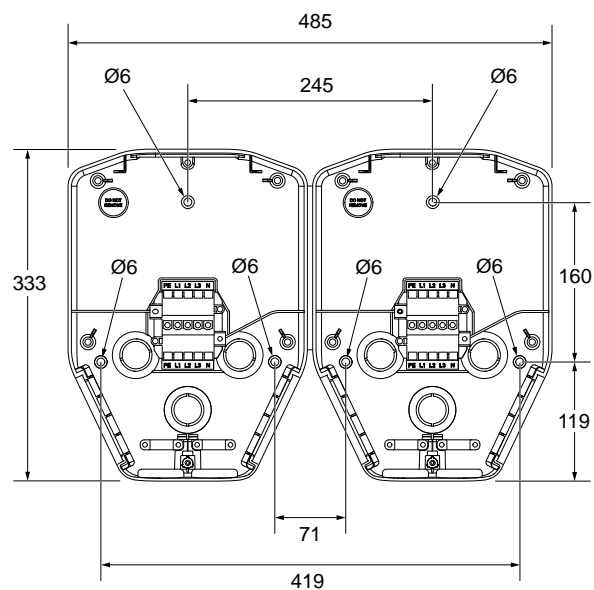

Bracket and knockout dimensions:

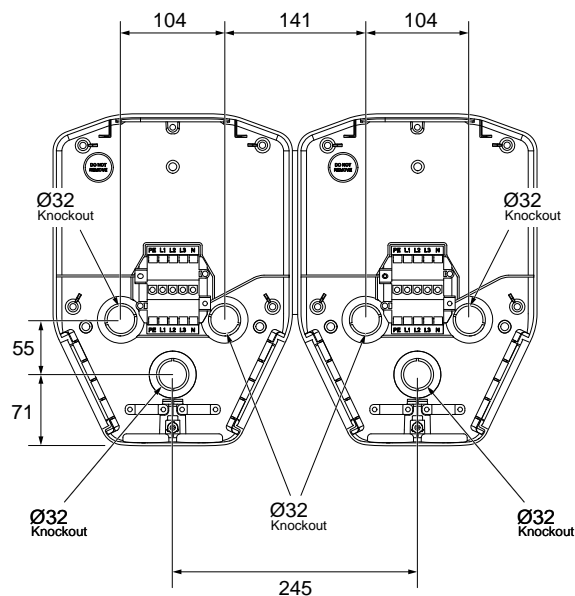
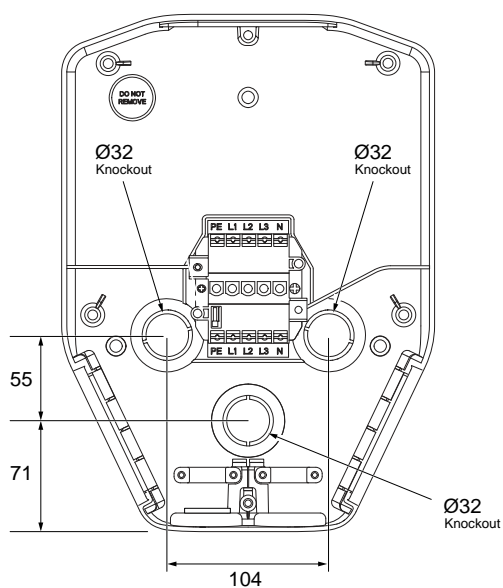

3.5.2 DOUBLE VERSION INSTALLATION BRACKET (IB)

Bracket and hole dimensions:

4 INSTALLATION

4.1 TO DO BEFORE INSTALLATION

- Make sure that the correct training is provided to do the installation.

4.2 PERSONNEL REQUIREMENTS

- To safely and correctly install the charging station, only a certified installer or somebody who acts on behalf of a certified installer may perform the installation. Comply with local requirements.
- Only a technically skilled person with the necessary knowledge of the GARO Entity charging station may replace the charging unit.

4.3 PERSONAL PROTECTIVE EQUIPMENT

WARNING

Make sure that the correct personal protective equipment for the installation is available. Adapt the personal protective equipment to suit the installation location. Comply with local requirements. Note that more personal protective equipment can be necessary.

- Protective shoes for electricians.
- Protective gloves.
- Protective goggles.
- Protective helmet.
- Hearing protection.
- High visibility clothing.



4.4 TO DO A PLAN FOR THE INSTALLATION

- Prepare the installation location according to the steps that are shown in the illustration.

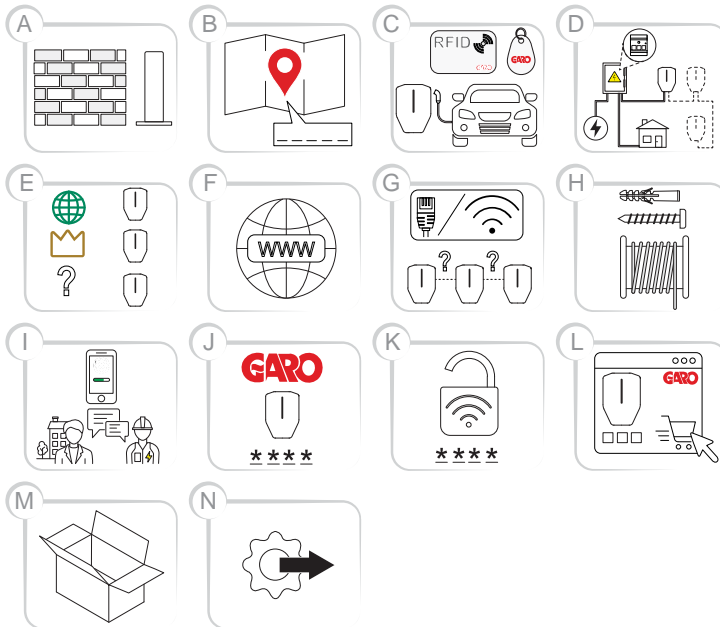

- A. Decide where to put the charging station(s).
Make sure that the location is suitable due to weather conditions and preparation for future expansion.

NOTE

Charging station(s) can be attached to a wall, a stand or a pole. Installation accessories are available at GARO.

- B. Decide on how to define the location and naming of the charging station(s).
- C. Decide on access control for EV drivers. It is possible to control access with the GARO Connect app or RFID tags where controlled authorization is necessary. Those can also be combined in a schedule.

NOTE

RFID tags are available as accessories at GARO.

- D. Plan the power supply and current availability on all levels of the installation. Plan for the DLM (dynamic load management) system setup. Refer to [4.13.1 Dynamic Load Management \(DLM\) functionality, page 43](#).

- E. If several charging stations are used, decide which unit (charging station or load interface) that should act as master unit. This can be affected by a DLM setup.

- F. Decide the internet connection type for the master unit in the connection group (the charging station or a load interface unit(s) managing this role).

- G. Decide the connection type between all charging stations, if applicable. If large connection groups are needed for DLM the connection structure needs to be divided into a group structure, with max. 32 units in each group preferably following the DLM structure, and when a mesh Wifi grid is required to be set up.

- H. Make sure that the necessary tools and testing instruments for installation are available.

- I. Make sure that the correct installation material is available.

- J. Decide if the installer or owner should prepare the installation in the GARO Connect app. Refer to [4.14 GARO Connect, page 56](#).

- K. Use the GARO Connect app to generate the installation code. The owner normally provides the installation code to the installer. However, the first installation can be made by the installer and handed over to the owner.
- L. Prepare the Wi-Fi credentials (SSID and password), if Wi-Fi is used for internet connection. The owner of the local Wi-Fi then needs to provide the Wi-Fi credentials to the installer.
- M. Order the required products, accessories and other material.
- N. Unpack the packages from GARO. Inspect the product(s) and accessories while unpacking to make sure that no damage has occurred during transport. Also, make sure that all the necessary product(s) and accessories are available, before the installation is started.
- O. Start the physical installation.

4.5 TO GENERATE THE INSTALLATION CODE

An installation code is used as a key to the location. It is created and used in the GARO Connect app. An installation code must be provided to the installer for correct installation of the charging station. The installation code is owned and generated by the owner. An installation code provides access to a location.

NOTE

A new installation can also be started by the installer that acts as an intermediate owner, which means that the installer hands over the ownership after installation is completed.

NOTE

If the installer no longer shall have access to the location, generate a new installation code.

NOTE

There can only be one installation code for each location. However, an installation code can be used by several installers but only 1 installer shall be formally responsible for the installation work. Refer to [To prepare the installation \(owner\)](#), page 61.

4.6 TO DO A CHECK OF THE DELIVERY

- Make sure that the delivery is complete and correct.

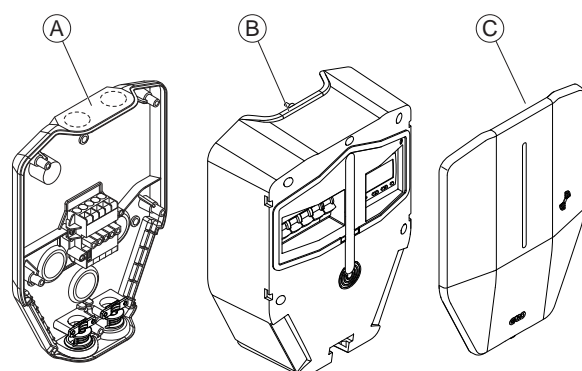
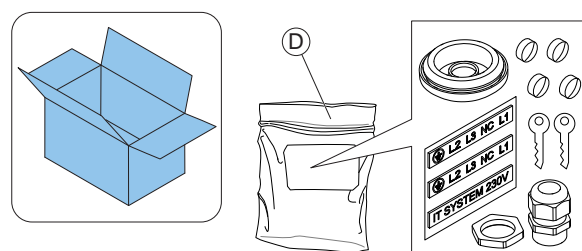

- A. Installation bracket
- B. Charging unit
- C. Front cover
- D. Bag with 2 keys, 2 types of cable grommet, 4 screw covers and 2 stickers (for the IT 230 V system)

4.7 TO ENSURE THE NECESSARY TOOLS

- Make sure that the necessary tools for the installation are available.

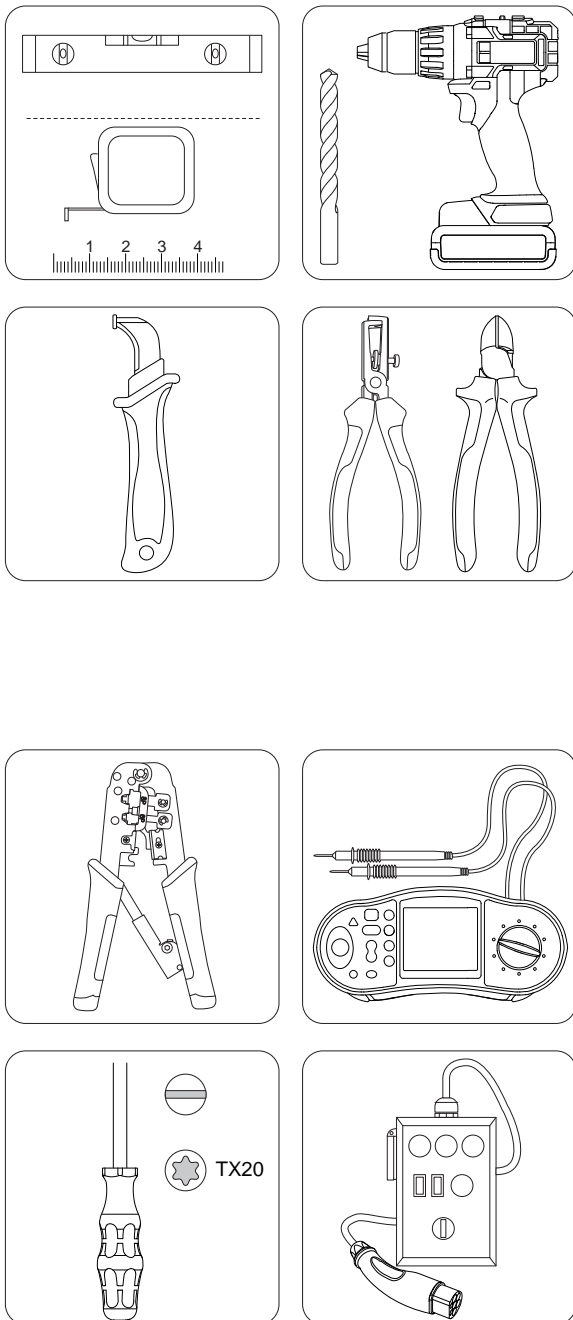

4.8 TO ENSURE THE NECESSARY INSTALLATION MATERIAL

- Make sure that the necessary installation materials are available.

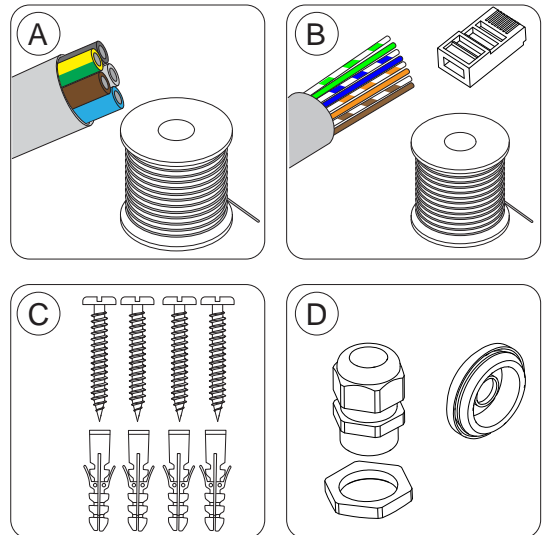

- A. Power cable.
- B. Ethernet cable with suitable RJ45 plug, if ethernet is used.
- C. Screws and plugs that are suitable for the wall material, at a maximum diameter of 6 mm and a maximum screw head diameter of 14 mm.
- D. Cable grommets (M32) that is suitable for the entry point of the power cable. The product is delivered with a cable grommet (M32). For cables that enter from the top or bottom of the charging station, use a IP54 cable grommet with an integrated cable strain relief function as a minimum requirement. If mounted at the back, use the skin.

4.9 TO DECIDE INTERNET CONNECTION TYPE

- Decide what internet connection should be used for the installation and what unit that should be used for the role of communication master. There are 3 types of internet connection that is possible to use for installation.

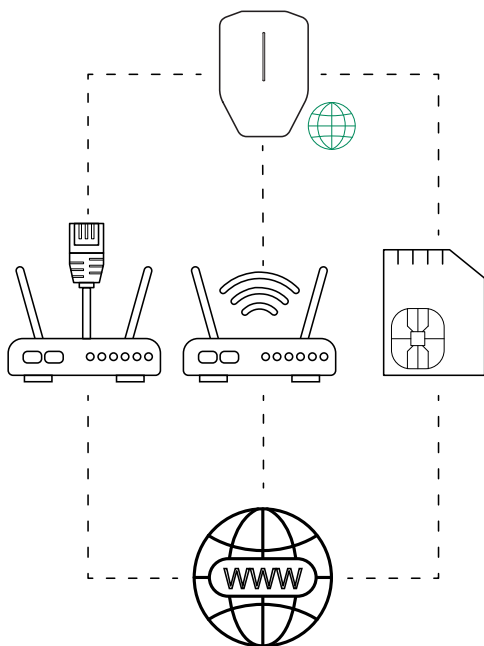

- Ethernet cable from a new or existing router/switch.
- Local Wi-Fi connection from the building where the installation is set up.
- Built-in mobile communication modem (Cat-M1/NB/GPRS) with SIM card.

NOTE

The listed order is also the automatic priority order for connection types.

- Large groups are recommended to be connected using an external internet router and an ethernet cable whenever possible.
- The built-in modem in a charging station is to be considered as the last option and only for providing internet to small systems.

4.10 TO CONNECT SEVERAL CHARGING STATIONS

NOTE

Several charging stations can be connected as one cable multidrop/daisy chaining. Maximal prefuse is 80A type C.

If DLM is used, all charging stations must be on the same LAN/IP-network.

4.10.1 BEFORE SETUP

Before choosing the connection type between several charging stations, first choose the internet connection type for the master charging station.

After selecting internet connectivity, it is time to plan for the inter-connectivity. There are 3 connection types available: 1) ethernet cable, 2) Wi-Fi (through the LAN of a building) or 3) mesh Wi-Fi.

All units are connected through a group structure of connection groups for communication. In most cases, those groups can follow the group structure of the DLM power distribution. The exceptions are mainly large groups on same DLM level (>32 units) or when inter communication is changed to start a mesh Wi-Fi group.

NOTE

A connection group, setup by assigning a communication master role to a unit, is limited to max. 32 units. If more units need to be used in the system, then subgroups need to be introduced.

A unit acting as master for a subconnection group must be connected via an ethernet cable or Wi-Fi to the LAN.

A meshed Wi-Fi group must be "started" by a unit acting as communication master.

Several mesh Wi-Fi groups can be set up, but only in parallel, not as a "meshgroup" of a meshgroup.

A mesh network is dynamically optimizing the connection paths used. All units in the meshgroup are acting as a repeater, but always just "mesh in- mesh out". So mesh is a good alternative "far out" in a network when cable cannot be used.

External IT-infrastructure is usually required to build large installations. As long as the same LAN (VLAN) is used, it is recommended to use cable-based internet through a router, or if not possible, a mobile communication-based router.

The external IT-network is built up of switches, preferably forming star-connected networks. However, the built-in 2-port switch of the Entity PRO charging station and Entity Balance Advance, can be used to build a long chain of installation. A disadvantage is that a service break in one unit disturbs the units that follow.

The mesh Wi-Fi system contributes to an easy installation. However, large distances or radio obstacles may require physical ethernet cable connections. Cable connection is a good recommendation.

Units can also be inter-connected through an existing Wi-Fi. However, this requires that the Wi-Fi is a part of the same LAN that the other units are connected to. One example is when a "radiojump" is required, longer than a normal Wi-Fi range, then any external point-to-point ethernet extender can be used. The use of a Wi-Fi makes the installation and the replacement of a charging unit more complex. A non-master unit can never just be "plug and play" replaced if a Wi-Fi is used as connection type.

NOTE

A system of charging stations is always highly dependent on both internet connectivity and a robust inter-communication based on traditional LAN-technology.

4.10.2 SIMPLE SETUP SCENARIOS

The connection type between the master charging station (A) and the other charging stations (B, C, D) in the same installation depends on distance and radio obstacles. The following scenarios are some common setups when you have several charging stations.

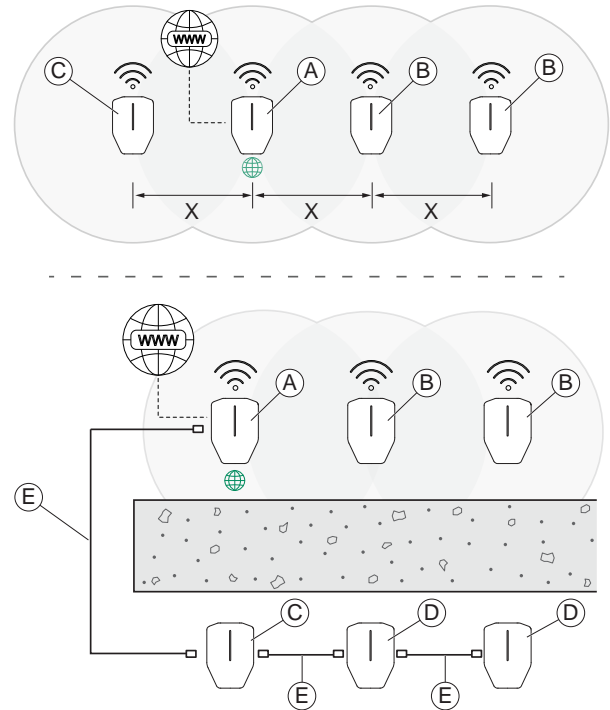

Scenario 1: If the distance (X) between the charging stations is short and there are no radio obstacles, it is possible to use a mesh Wi-Fi connection between the master charging station (A), and the other charging stations (B and C). However, it is always preferable to use an ethernet cable.

Scenario 2: If the distance between the master charging station (A) and the charging stations (C) are long or there are thick walls or other radio obstacles, an ethernet cable or other external LAN infrastructure (E) must be used. If there are several charging stations (D) behind the obstacle, they can all be connected to a chained connection from a charging station (C) with an ethernet cable as long as each cable distance is not too long (recommended maximum 100 m).

4.10.3 CONNECTION GROUP HIERARCHY

The workflow of adding units shall follow the internet connectivity path while forming the DLM structure. This means that the workflow always begins with the unit acting as internet connectivity master. From this unit, the whole structure can be defined using 4 main methods to add a charging station in relation to already built parts. The workflow must follow the DLM relational paths.

New units that are a part of a DLM system must be added (connected) to groups. There are 4 main ways to do this:

- Add the unit to an existing group.

This the most common setup. It is used to add a new unit to an existing group.

One example of this is adding a load interface, to take over the DLM master role of a group. The picture below shows adding a charging station.

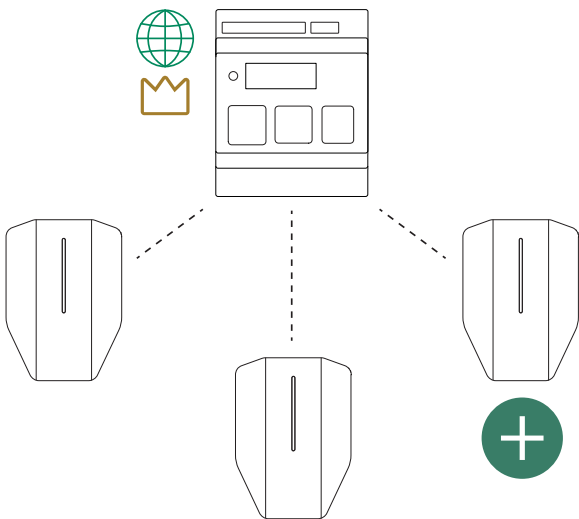

- Create a new subgroup.

This method is used to add DLM control to a new subgroup of charging stations either with a charging station acting as DLM master or a load interface acting as master. The subgroup receives its power from the first group. This means that the first group's fuse is used on a higher level for both the first group and the new subgroup.

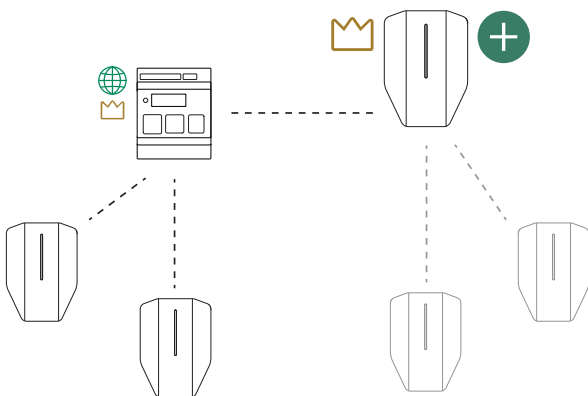

- Create a new superior group.

This method is only used for adding a load interface acting as DLM master 1 level up. Use this when a existing group requires a dynamic DLM, that is a DLM master that monitors/measures current in a feeding fuse. Applicable when the critical fuse to protect also feeds both charging stations and other non-controlled loads.

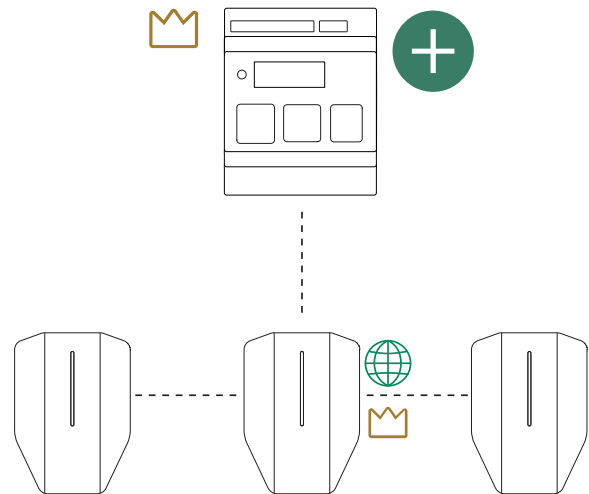

- Create a new stand-alone group.

This method is used to directly connect a unit to a new unique group. The unit is not directly connected to any other group. It is mainly used to form another, separate DLM system at same location.

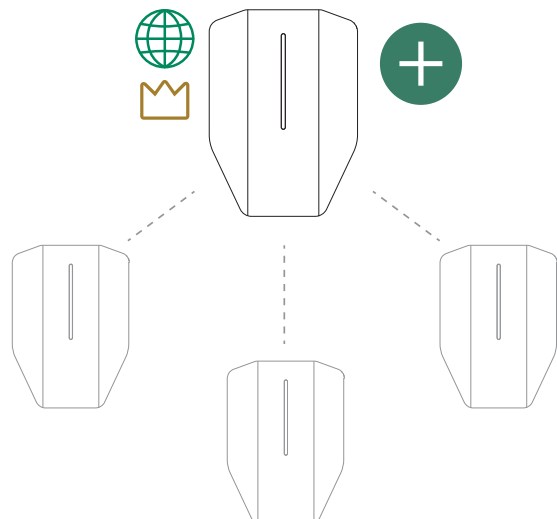

4.11 TO DECIDE THE POSITION OF THE CHARGING STATION

1. Avoid installing the charging station where snow (A) can block access to the charging station.

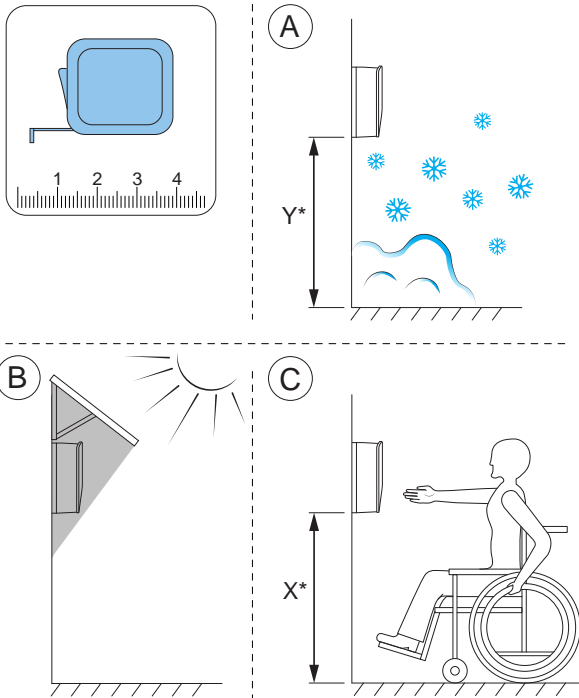

2. Avoid installation in direct sunlight (B) and do not install the charging station on a hot surface.
3. Make sure that the position of the charging station is approved from an accessibility (C) perspective. Comply with local requirements.

4.12 CABLE INSTALLATION

The GARO Entity is designed to work with both 400 V TN-S (default) and 230 V IT/TT.

If a 230 V IT system is to be used, the marking of the installation bracket should be updated, using the supplied marking stickers.

Once connected, the charging station will detect what voltage system it uses. The only setting required is phase connections. Refer to [4.12.5 To connect the power cable to the terminal, page 31](#).

As retro-fit, a charging station (CS) may need to be installed to a 400 V TN-C. However, TN-C is not

recommended and requires that the PEN conductor area is considered.

- Case 1: Use one side of the installation terminal to "create" the N, bridge N and PE. Connect PEN to the PE terminal.

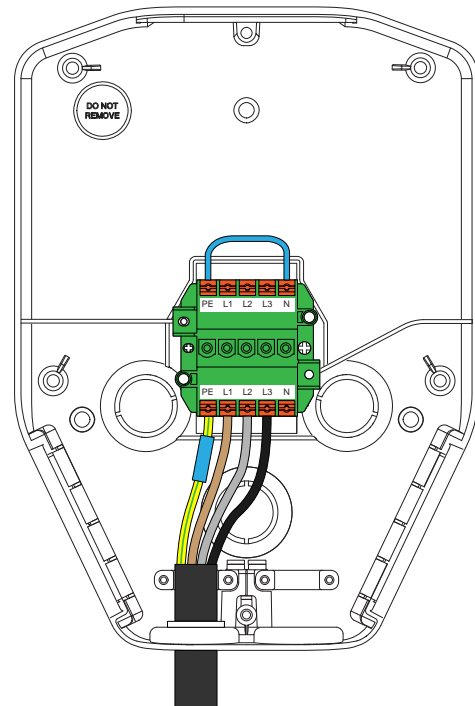

- Case 2: In a daisy-chain connection it is recommended to use green/yellow tape, blue tape and connect the PEN according to the picture.

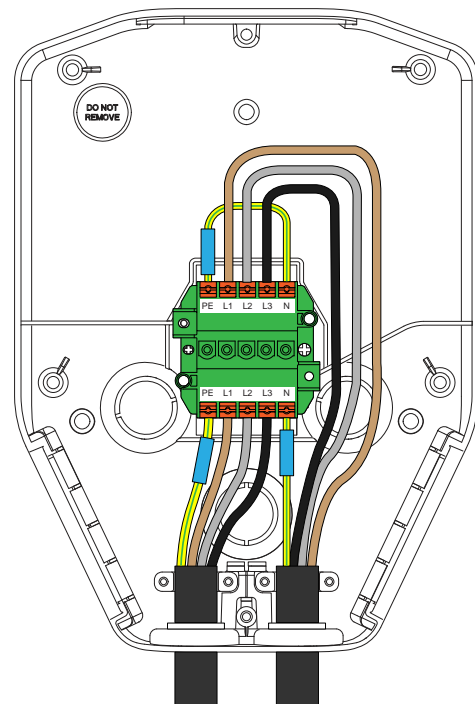

As alternative, a separate PEN terminal block with 3 terminals, to be used for with "creation" of a neutral conductor, can be used.

4.12.1 TO INSTALL THE STICKERS FOR IT 230 V

NOTE

This instruction is only valid for IT 230 V systems.

1. Locate the stickers on the installation bracket.

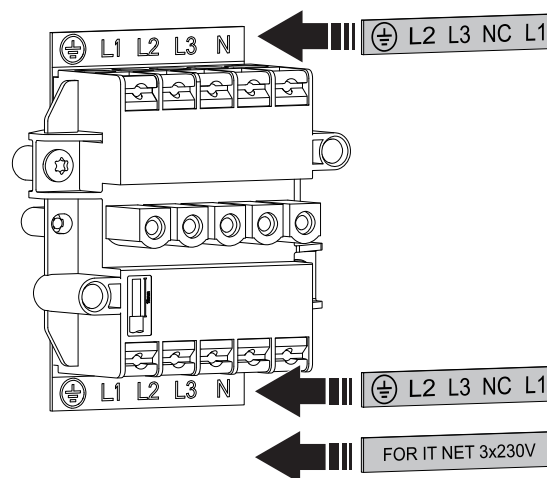
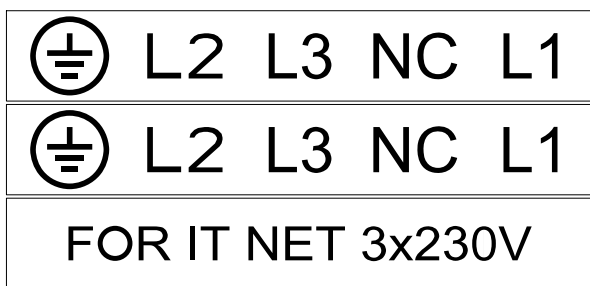

4.12.2 TO PREPARE THE INSTALLATION BRACKET FOR THE CABLE INSTALLATION

1. Decide the inlet points for the power cable.

2. Install the new stickers supplied with the installation bracket. Install the new stickers onto the old stickers.

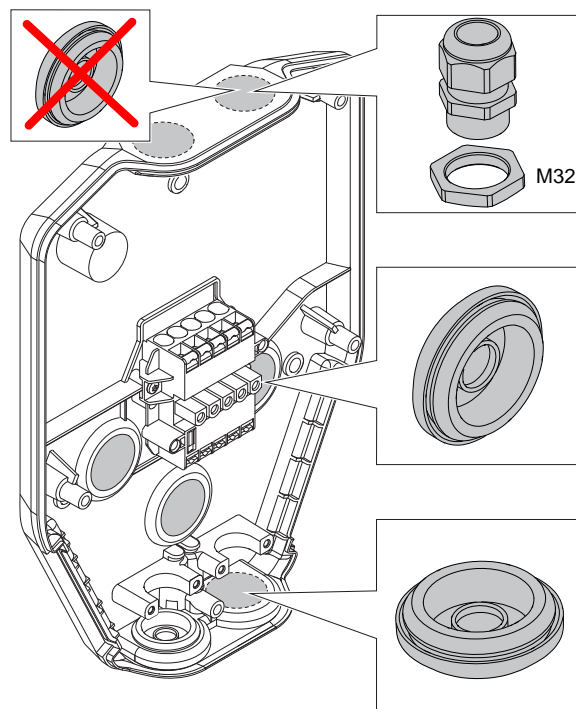

- a. Remove the knock-out from the inlet hole of the power cable.

- b. If there are several charging stations to be daisy-chained with the same feeding cable, also remove the knock-out for the outlet hole of the second power cable.
 - c. Insert a suitable grommet in the knock-out hole.
2. If the connection to internet, or other charging station, is decided to be via an ethernet cable, prepare the inlet of the ethernet cable(s).

NOTE

It is possible to install the ethernet cable in several ways, but there are dedicated break-outs for the ethernet cable in the installation bracket. Maximum cable diameter for the break-out is 8 mm. To seal the hole, either use a non-silicone material or simply put a piece of tape on the cable to achieve a firm fit. A cable-tie can be used for strain relief.

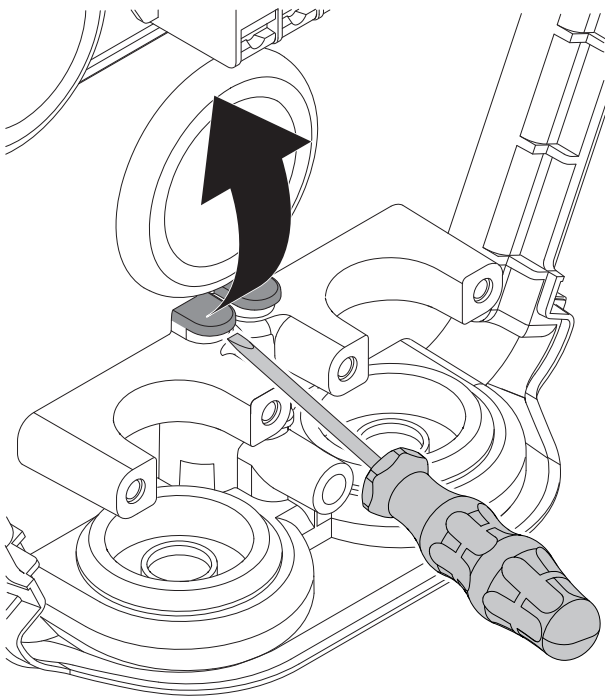

NOTE

If the top cable entry positions are used, they must be firmly sealed with approved IP54 cable grommets. The cable grommets must also secure cable force strain relief. The lower and rear positions are preferably sealed using "skin type" cable grommets.

4.12.3 TO INSTALL THE INSTALLATION BRACKET TO A WALL

1. Decide the position of the charging station. Refer to [4.4 To do a plan for the installation, page 20](#).
2. Hold the installation bracket as a template against the wall.

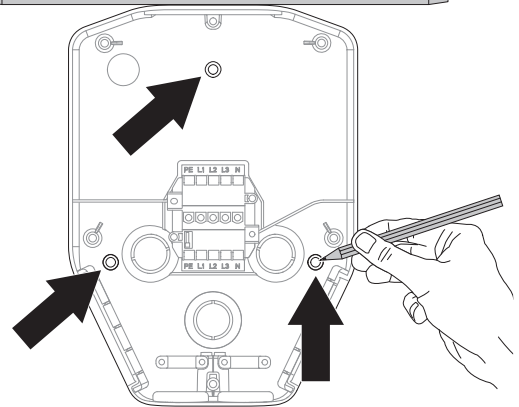
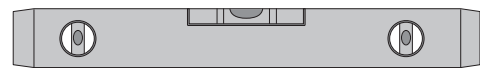
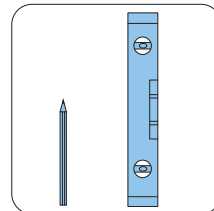

3. Use a spirit level to make sure that the installation bracket is straight.
4. Use a pen to mark the drill holes on the wall, if needed. Refer to [3.5 Dimensions, page 16](#) for the bracket hole positions.
5. Choose appropriate screws for the wall material. If it is necessary, also choose appropriate plugs and drill for the wall material.

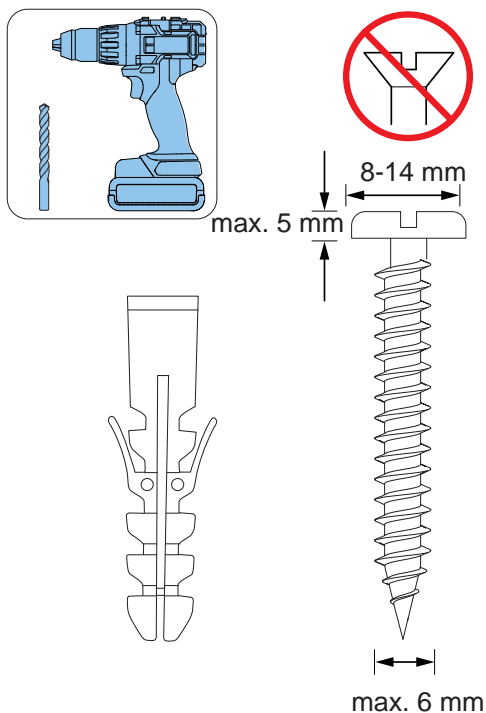

6. Drill the holes and attach the plugs if it is necessary.
7. Attach the installation bracket to the wall with the screws.

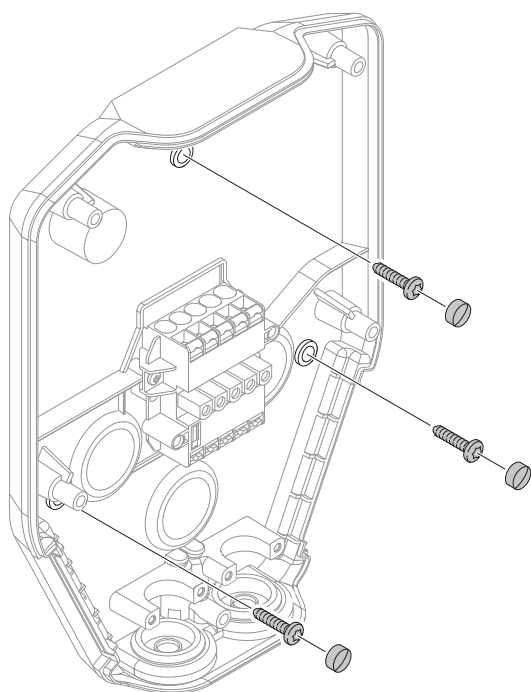

8. Attach the screw covers to the screws.

NOTE

Ground stands and polemount fixtures are available as accessories. The workflow is similar. See separate manuals for those accessories.

4.12.4 TO PREPARE THE POWER CABLE FOR INSTALLATION

CAUTION

If it is necessary to pass the connection terminal with connection of the power cable due to dual power cables in the same direction, route the wires on the opposite side from the connection terminal, compared to where the Type 2 outlet is to be placed (right or left). For example, if the Type 2 outlet is located on the right side of the charging unit (default), lead the wire on the left (A) side of the connection terminal. If the Type 2 outlet is located on the left side of the charging unit, lead the wire along the right (B) side of the connection terminal. Refer to [3.4 Charging station overview, page 15](#) to see where the Type 2 outlet is.

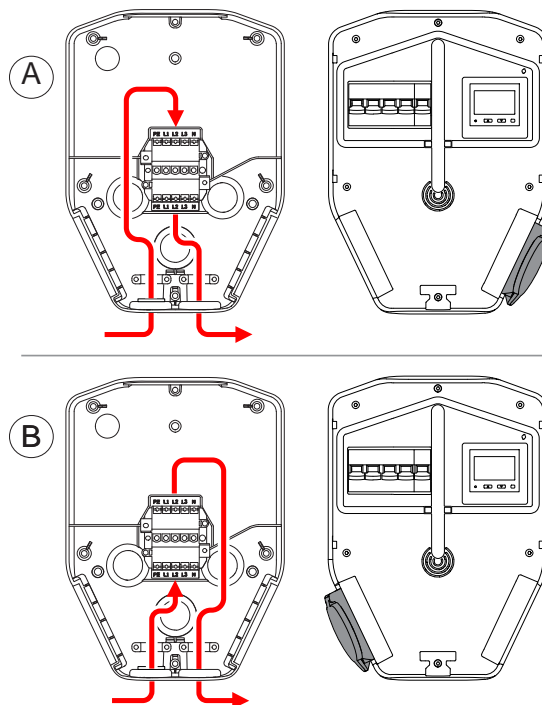

1. Dismantle approximately 500 mm of the power cable.

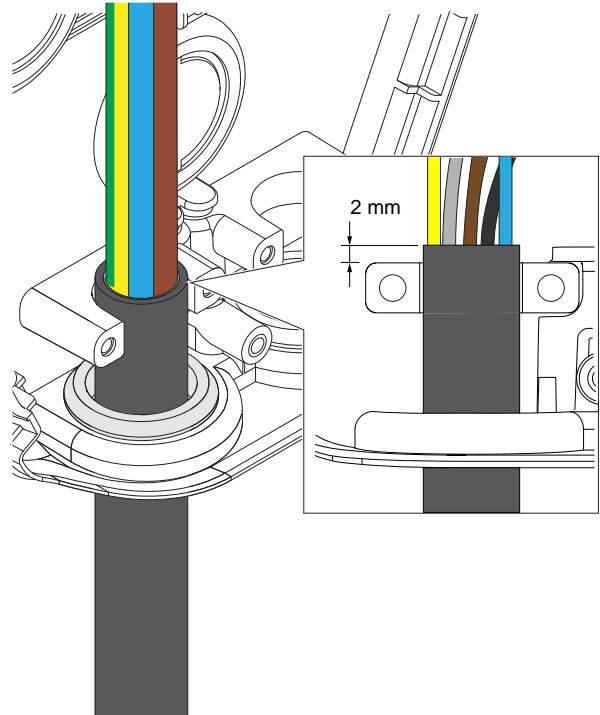
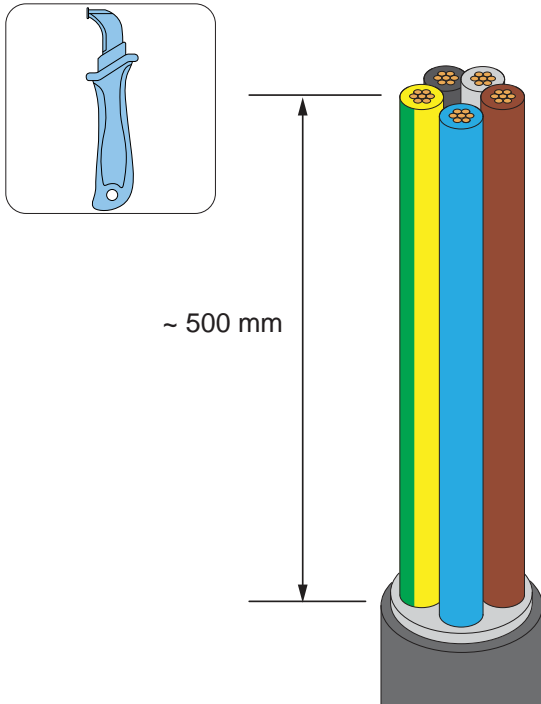

2. Thread the power cable through the grommet in the power cable inlet hole.

4. Install the cable strain relief to fixate the power cable.

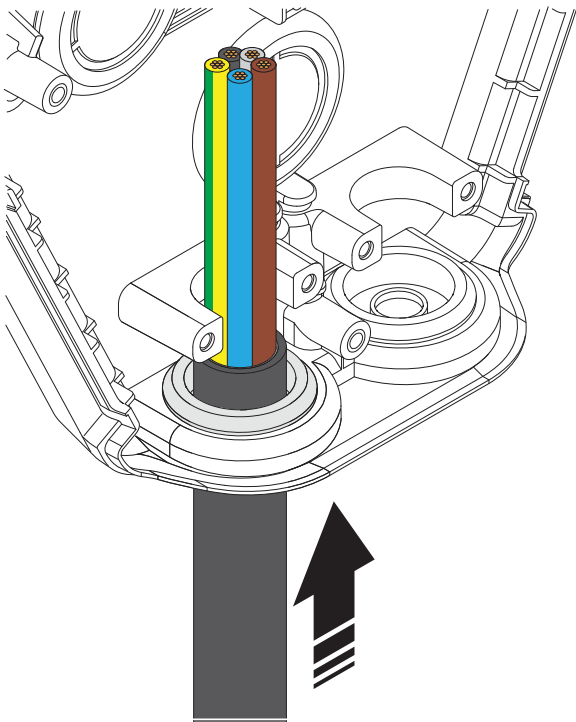

3. Make sure that the cable sheet reaches 2 mm above the bracket for the cable strain relief.

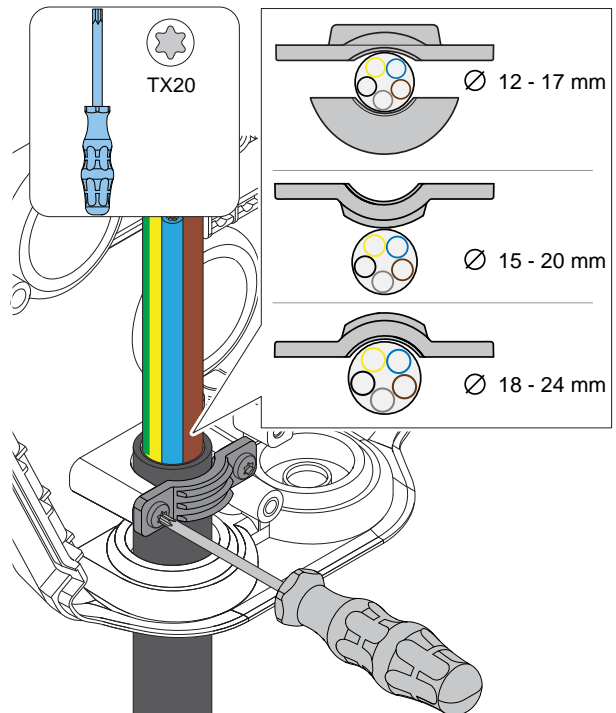

NOTE

The cable strain relief can be configured in 3 different ways. Choose the configuration that is suitable for the diameter of the power cable.

5. Cut the wires to the exact length for the installation.

6. Cut and dismantle the wires. Use a wire ferrule (A) for strained power wire conductors (B).

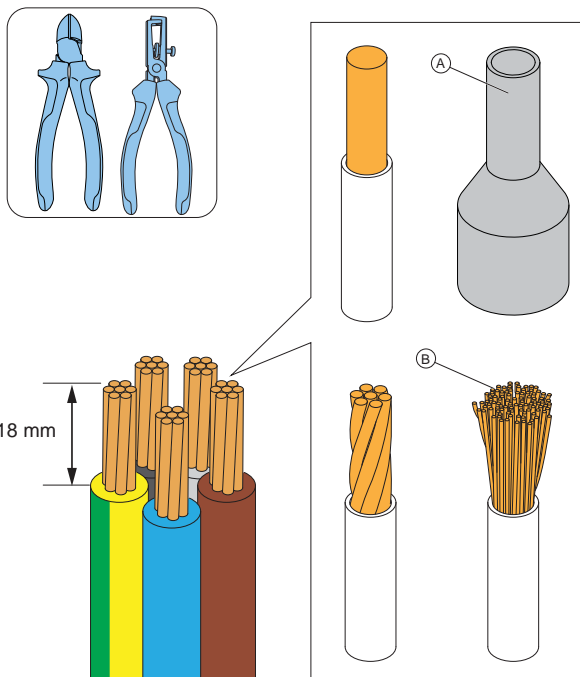

CAUTION

Make sure that the protective earth cable is a little bit longer than the other cables.

NOTE

It is highly recommended that the feeding fuse to all power cables are based on all-pole breakers (MCB/MCCB).

4.12.5 TO CONNECT THE POWER CABLE TO THE TERMINAL

Electric vehicles charge on one, (two) or three phases. Phase loads must be addressed, especially when installing several charging stations in one location. GARO Entity PRO is available with a built-in phase management system, that when using DLM, automatically selects the phase(s) that can be used. This means, that the charging stations involved can be installed as L1 to L1, L2 to L2 and L3 to L3.

If charging units without this function are used, it is highly recommended to rotate phases one step for each charging station. The rotation must also be configured

in the GARO Connect app to reflect exactly how each charging station is connected to the grid.

Another reason to install charging stations with rotation between all stations is that if many one-phase vehicles are charging, the DLM may perform better in keeping three-phase charging in use. The reason for this is because the used phases will be more evenly distributed.

Install the power lines as follows:

1. Install the wires of the power cable according to installation type.

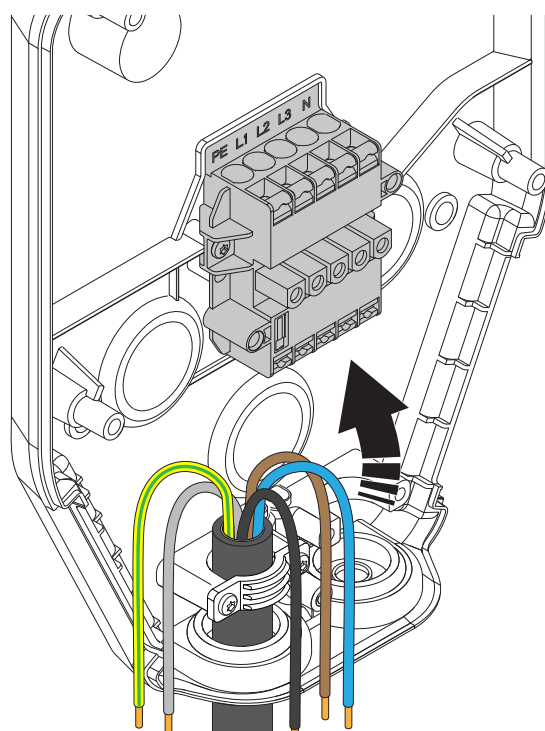

a. TN system.

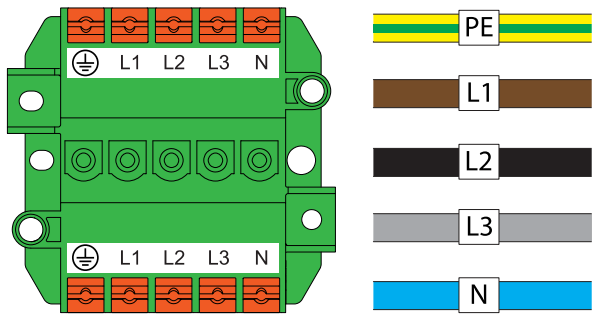

TN400 V

PE	L1	L2	L3	N	Description
PE	L1			N	TN 1x230V L1
PE	L2			N	TN 1x230V L2
PE	L3			N	TN 1x230V L3
PE	L1	L2		N	TN 2x230V L1 - L2
PE	L2	L3		N	TN 2x230V L2 - L3
PE	L3	L1		N	TN 2x230V L3 - L1
PE	L1	L2	L3	N	TN 3x400V
PE	L2	L3	L1	N	TN 3x400V rotated + 120 deg
PE	L3	L1	L2	N	TN 3x400V rotated + 240 deg

b. TNC.

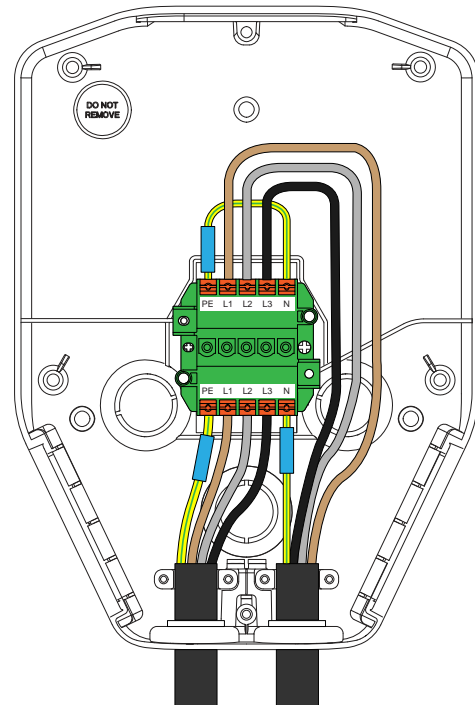
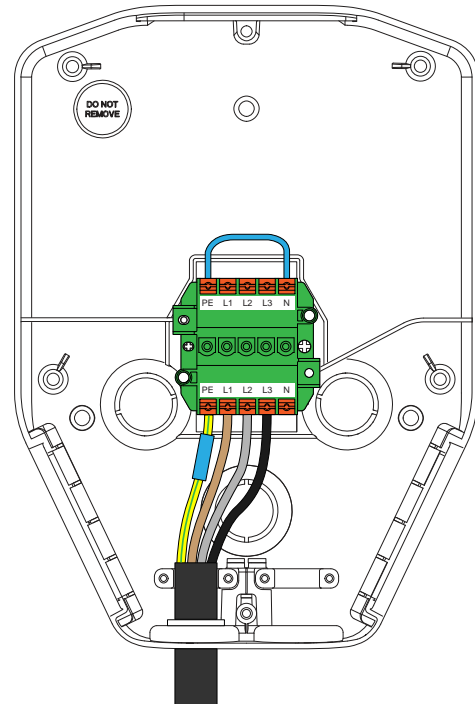

c. IT system.

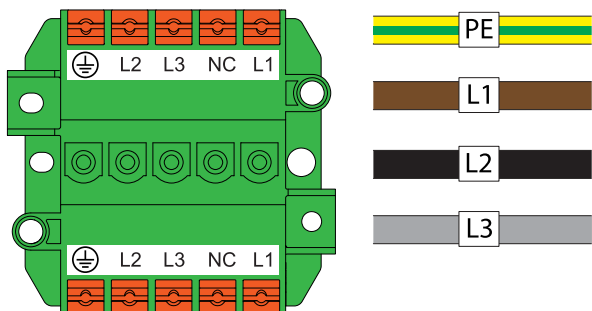

IT230 V

PE	L2	L3	NC	L1	Description
PE	L2			L1	IT 2x230V L1-L2
PE	L3			L2	IT 2x230V L2-L3
PE	L1			L3	IT 2x230V L3-L1
PE	L2	L3		L1	IT 3x230V
PE	L3	L1		L2	IT 3x230V rotated +120 deg
PE	L1	L2		L3	IT 3x230V rotated +240 deg

2. Install the wires to the terminal block.

- a. If the wires have strained conductors (A), use a TX20 screwdriver and push the orange button to open the terminal.
- b. If the wires have cable ferrules (B) or solid conductors (C), push the wires into the terminal.

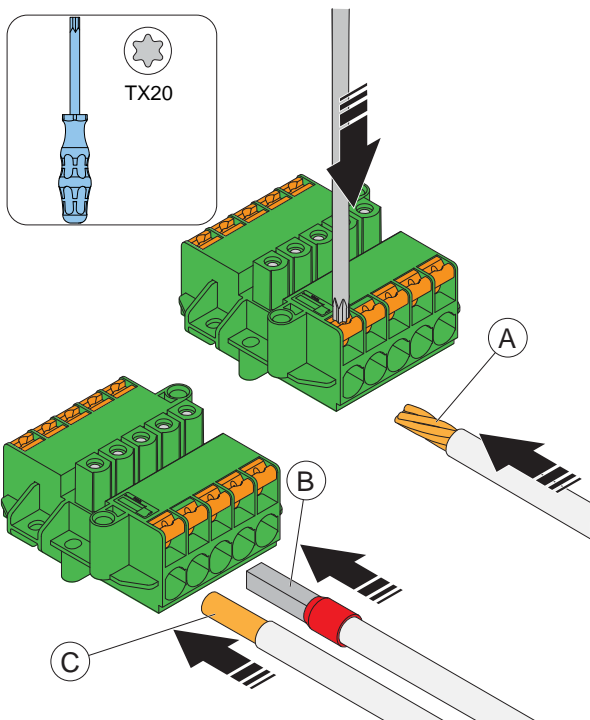

3. To remove any wire, push a TX20 screwdriver on the terminal and pull the wire out.

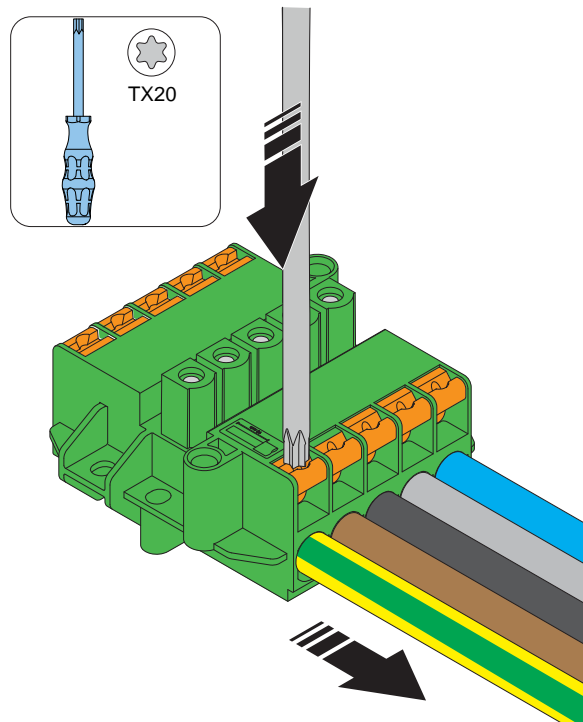

4.12.6 TO INSTALL A SECOND POWER CABLE (DAISY-CHAINING METHOD)

If several charging stations are fed by the same power cable in a daisy chain, a second power cable can also be connected to the terminal.

1. Dismantle the second power cable for installation. Refer to [4.12.4 To prepare the power cable for installation, page 29](#).
2. Install the wires of the second power cable to the terminal. For more information about installation types, refer to [4.12.5 To connect the power cable to the terminal, page 31](#).

4.12.7 TO PREPARE THE INSTALLATION BRACKET WITH AN ETHERNET CABLE

If ethernet should be used, the installation bracket must be prepared with the ethernet cable.

1. Thread the ethernet cable through the installation bracket.

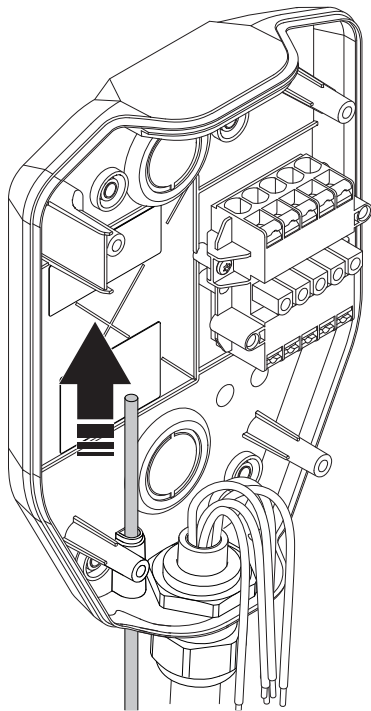

NOTE

The recommended length for the ethernet cable inside the installation bracket is 400 mm.

2. Secure the ethernet cable(s) from pull-out forces, for example with a cable strap.
3. Dismantle the ethernet cable.

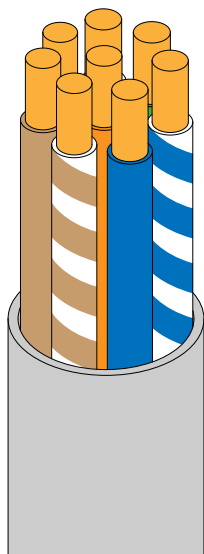
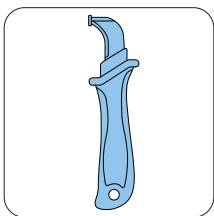

4. Put a piece of tape on the cable to increase the cable diameter and to tighten/seal the hole.
5. Install the ethernet cable to a RJ45 plug.

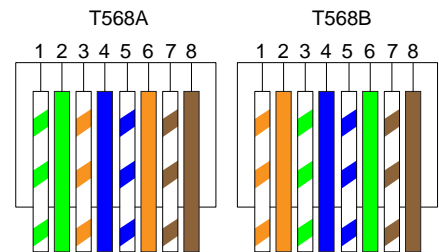
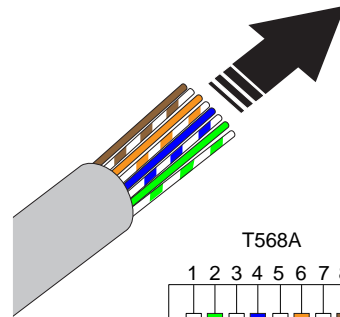
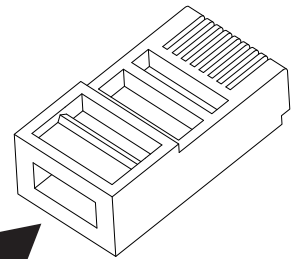
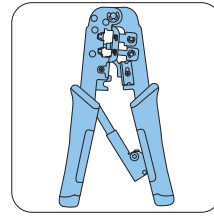

NOTE

Both shielded or unshielded ethernet cables are possible to use, depending on installation conditions.

4.12.8 TO PREPARE THE INSTALLATION BRACKET WITH A SECOND ETHERNET CABLE

If ethernet should be used as internet connection for several units (i.e. either charging stations or a load interface), the installation bracket must be prepared with a second ethernet cable. Refer to [4.12.7 To prepare the installation bracket with an ethernet cable, page 33](#).

- Install a second ethernet cable through the outlet hole in the installation bracket. Refer to [4.12.7 To prepare the installation bracket with an ethernet cable, page 33](#).

4.12.9 TO CONNECT THE CHARGING STATION TO THE INTERNET WITH COMMUNICATION MODEM (CAT-M1/NB/GPRS)

Connection to the internet with modem requires a SIM card (SIM card size: 3 FF = Micro = 15x25 mm).

1. Turn the charging unit rear side up.
2. Install the SIM card to the dedicated slot in the charging station.

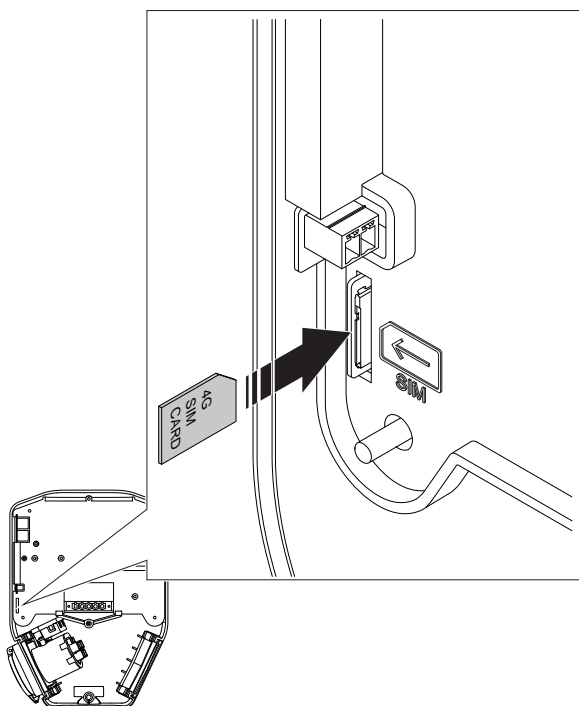

NOTE

Some charging units are supplied with a SIM card (standard) attached.

4.12.10 TO INSTALL THE CONTROL CABLE TO THE INSTALLATION BRACKET

NOTE

The charging station has a control input that can be used to enable and disable charging. This digital input signal limits the charging current to a fixed value 0-32 A (configurable). Physical connection is done by an external, insulated/potential-free contact. The control logic is configured in the GARO Connect app. By default, charging is disabled if the contact is closed. The control logic can be toggled: Closed contact = limitation, or Open contact = limitation. The current limitation level is configurable.

1. Thread the control cable through the inlet hole in the bottom of the installation bracket.

NOTE

The recommended length of the control cable inside the installation bracket is 500 mm. The maximum cable area for the control cable is 1.5 mm² and maximum voltage is 12 VDC and maximum current is 0.1 A. It is recommended to use a flexible and smaller cable area for convenient installation.

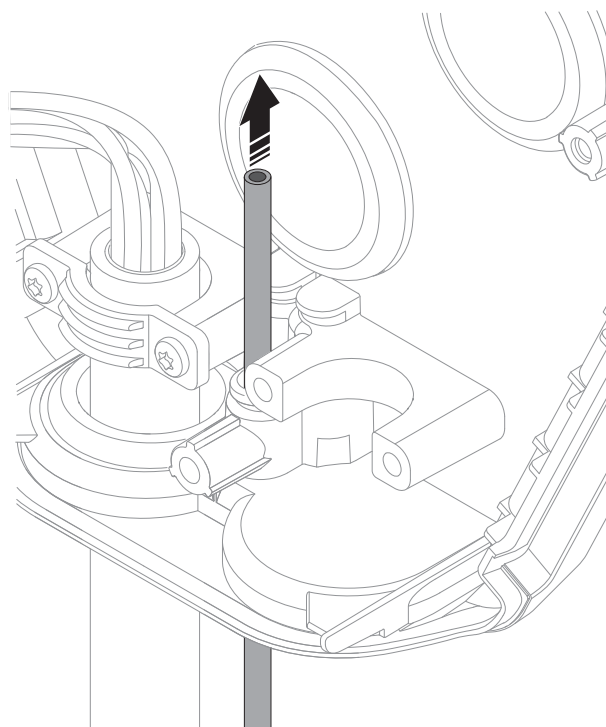

2. Secure the control cable from pull out forces, for example with a cable strap.

3. Dismantle the control cable and the wires inside the control cable.

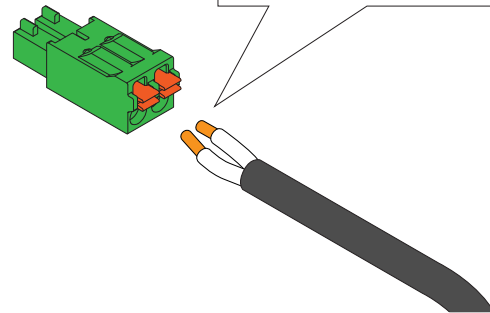
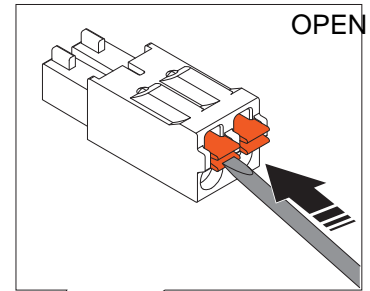
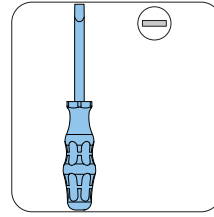
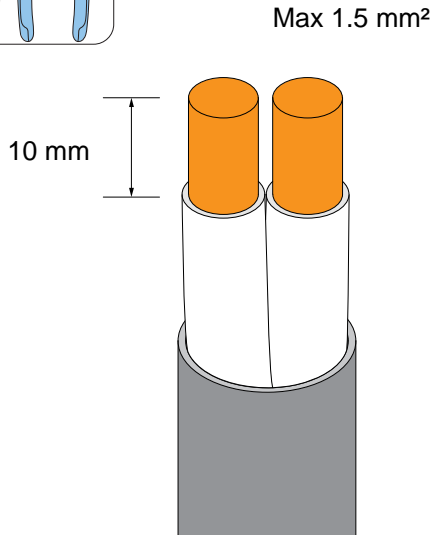
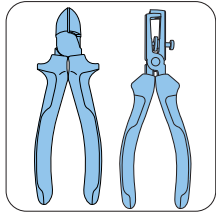

NOTE

The recommended conductor strip length is 10 mm.

4. If the cable has strained conductors, use cable ferrules to the conductors.
5. Install the cables to the connector.
 - a. If the cables have solid conductors or ferrules, push them into the connector.
 - b. If the cables have soft conductors, use a flat screwdriver to open the spring mechanism in the connector before you push the cable in.

NOTE

If wires need to be disconnected, use a flat screwdriver to push the orange button to open the terminal.

4.12.11 TO CHANGE THE POSITION OF THE TYPE 2 OUTLET OR FIXED CABLE

As default, the Type 2 outlet or the fixed cable is located on the right side of the charging unit. The position of the Type 2 outlet or fixed cable can be changed.

1. Turn the charging unit to the rear side.
2. Slide the Type 2 outlet or fixed cable (A) and the protective cover/cable holder (B) out of the charging unit.

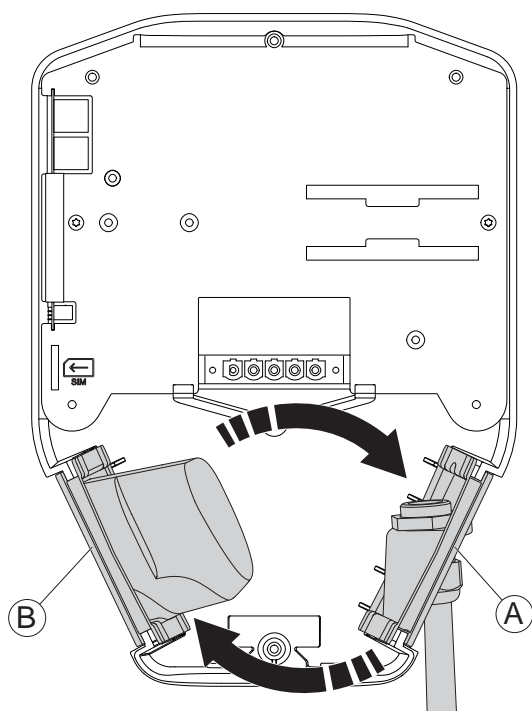
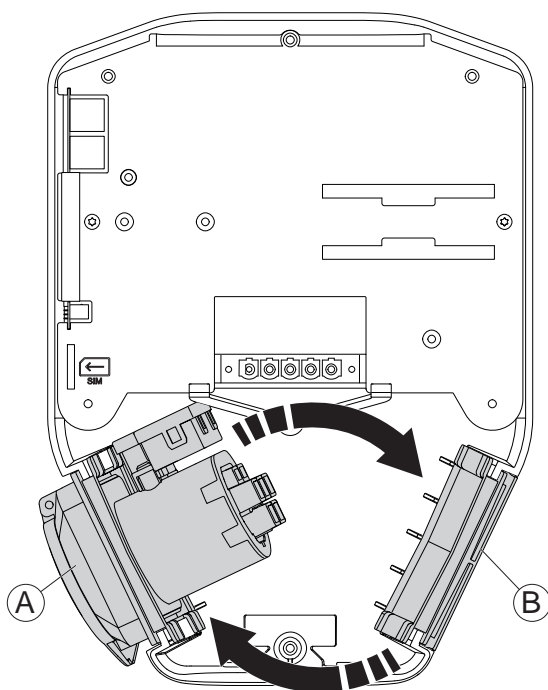

3. Install the protective cover/cable holder in the opposite slots.

CAUTION

Be aware of the wiring and make sure that the wires do not get pinched or stretched.

4.12.12 TO DO A TEST OF THE POWER CONNECTION

WARNING

Electrical power can cause serious personal injury or death.

1. Make sure that the power/voltage off by an appropriate insulating main switch.

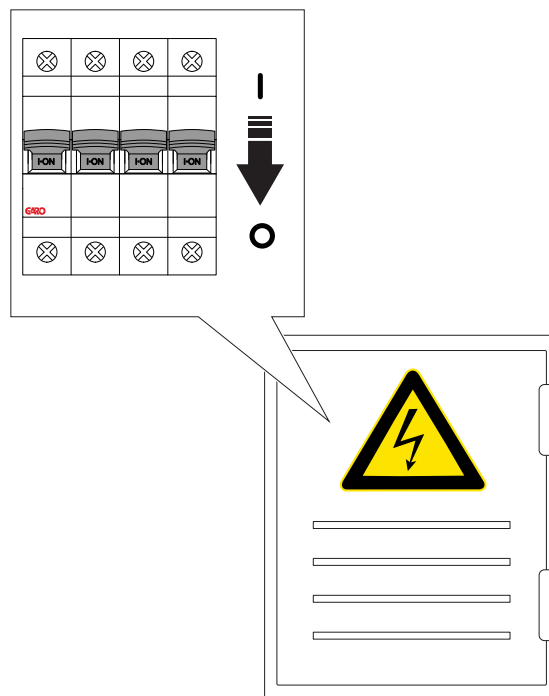

2. Do a visual inspection and make sure that nobody accidentally can access the installation bracket(s). Make sure that it is safe to apply power/voltage to all parts of the installation.
3. Do a test of the PE continuity.

CAUTION

Do not do a test of the insulation with any charging unit attached, as that can cause damages to the charging unit(s).

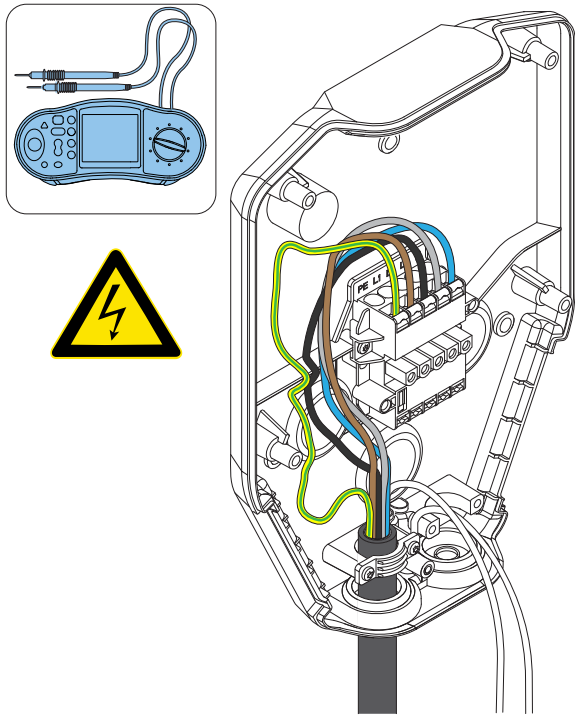

4. Switch the power/voltage to on.

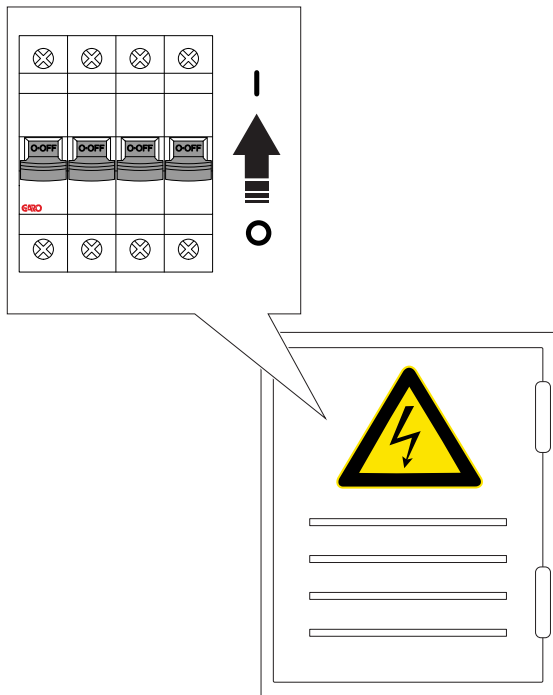

5. Do a check of the voltage and phase sequence in the installation bracket terminal. Make sure that the voltage and phase sequence matches the planned setup. Refer to [4.12.5 To connect the power cable to the terminal](#), page 31.

6. Switch the power/voltage to off.

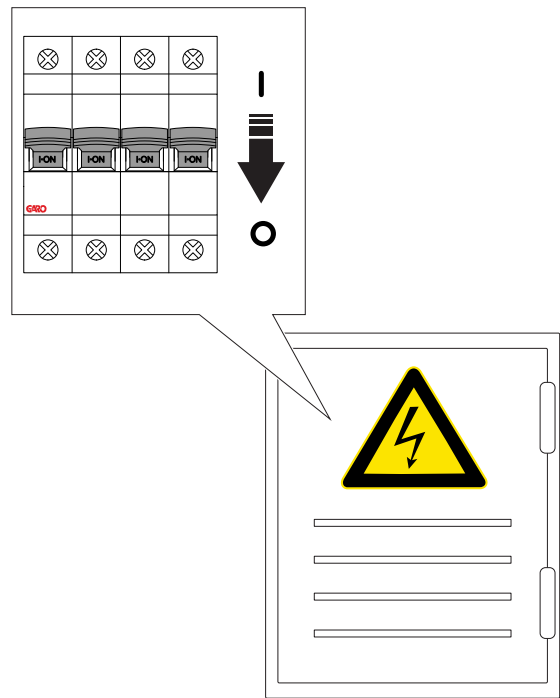

7. Read the QR code on the installation bracket using the GARO Connect App. At this step, it is time to connect the charging station, created in the GARO Connect App to the physical installation bracket. Refer to [4.14 GARO Connect](#), page 56 for more information about the procedure and functions of the GARO Connect app.

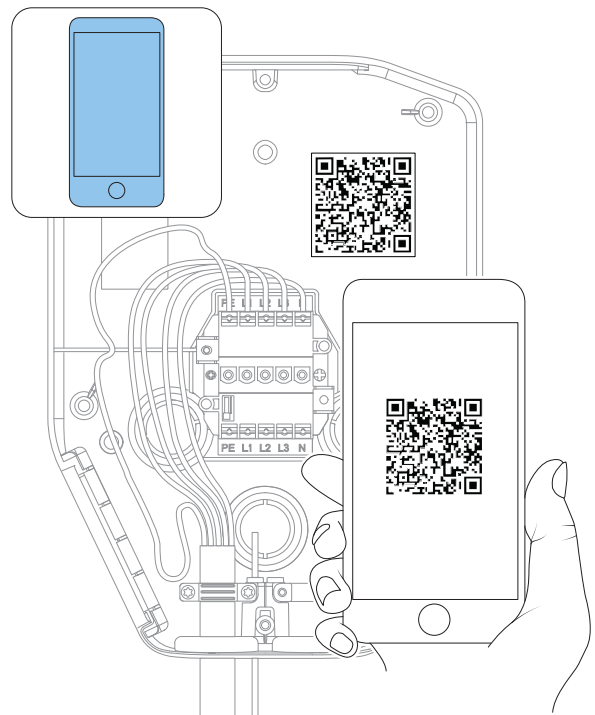

CAUTION

If the charging station is set up without any internet connectivity, it will allow charging at maximum current defined by the attached charging unit. The default setting is 16 A. Can be adjusted as parameter.

4.12.13 TO INSTALL A PROTECTION COVER

The protection cover is used to protect the installation bracket if a charging unit should not be attached from the start or temporary removed. When the protection cover is installed, the charging station is protected from damage before installation of the charging unit.

1. Attach the protection cover to the installation bracket.
2. Tighten the screws with a Torx TX20 until the protection cover is tight against the installation bracket (max. 2,9 Nm).

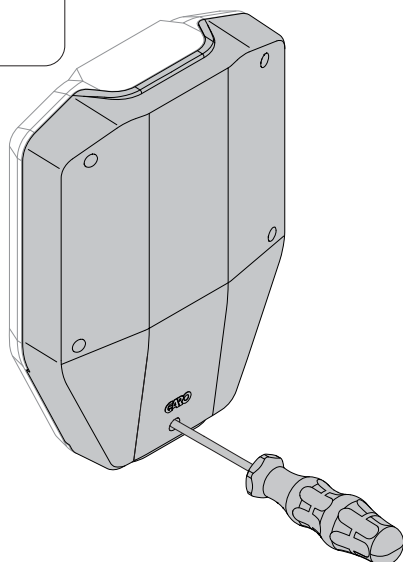
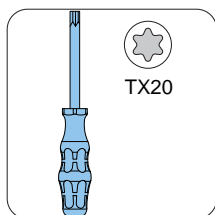

If the installation bracket is configured and prepared as a charging station, the function of the charging station is to be done using a charging unit.

After this test, the charging unit can be removed and replaced with a protection cover.

4.12.14 TO ATTACH THE CHARGING UNIT TO THE INSTALLATION BRACKET

1. If applicable, install the ethernet cable(s) in the ethernet ports on the charging unit.

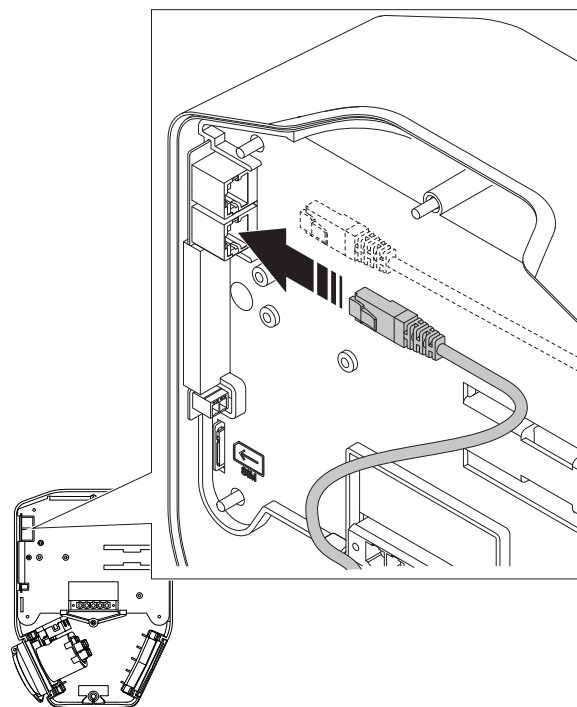

2. Install the control cable to the control cable port on the charging unit.

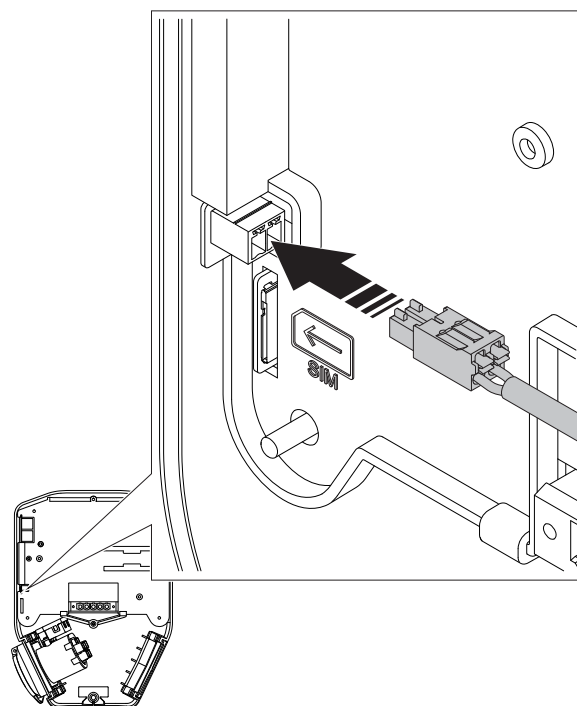

- Attach the charging unit to the installation bracket.
Press equally on the charging unit with both hands.

CAUTION

Make sure that no cables get pinched and that the charging unit can meet the edges of the installation bracket.

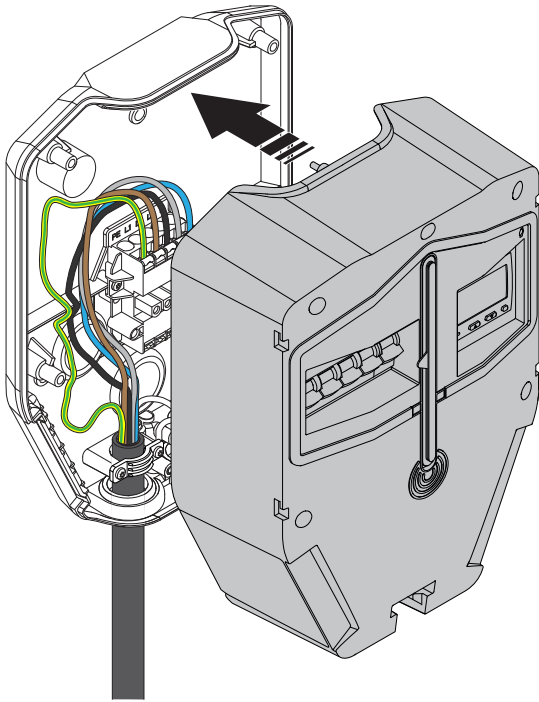

- Use a Torx TX20 and tighten the 6 screws until the charging unit is tight against the installation bracket (max. 2,9 Nm).

CAUTION

Do not overtighten the screws.

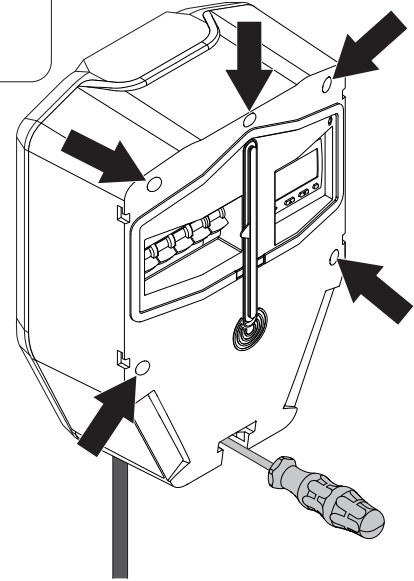
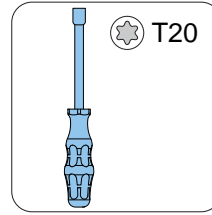

- Set the power/voltage to on.

WARNING

Electrical power/voltage can cause serious personal injury or death.

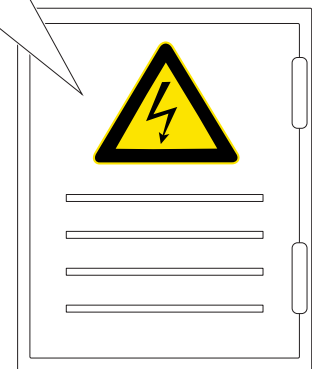
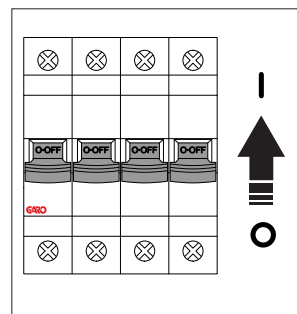

NOTE

If the charging station needs manual internet settings, that is if it shall act as a master with a local Wi-Fi as the internet connection, make the internet connectivity settings in the GARO Connect app. Refer to [To prepare the installation \(installer\)](#), page 68 .

4.12.15 TO DO A FINAL FUNCTIONALITY TEST OF THE PRODUCT

CAUTION

If the charging unit needs reduced installed current settings, make sure that this setting is done before testing with high power, such as EV charging.

1. Switch the power/voltage to off.

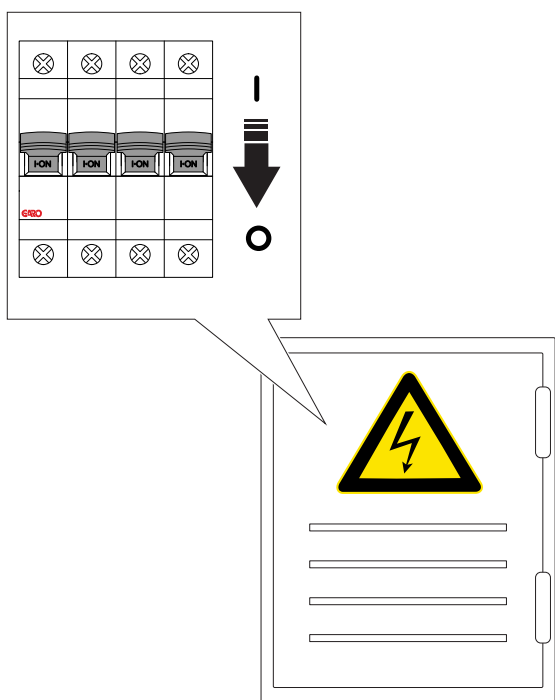

2. Do a test of the PE continuity to the Type 2 outlet.

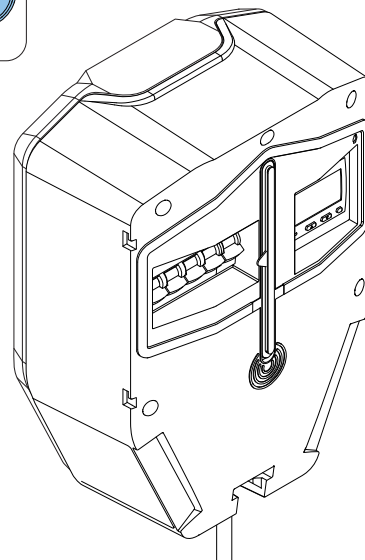
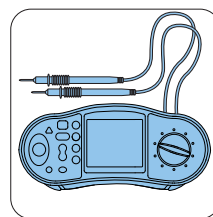

3. Switch the power/voltage to on.

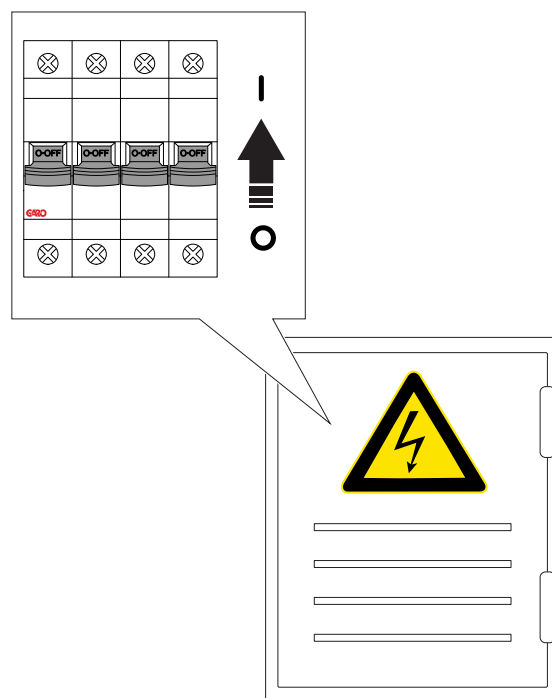

4. After the power/voltage is switched on, the charging station will start up. This can take up to 90 seconds. Progress is indicated by red LED segments on the indication light. A fixed green light indicates when the charging station is ready, given that the all-pole breaker is ON. If it is not, then the light will be red.

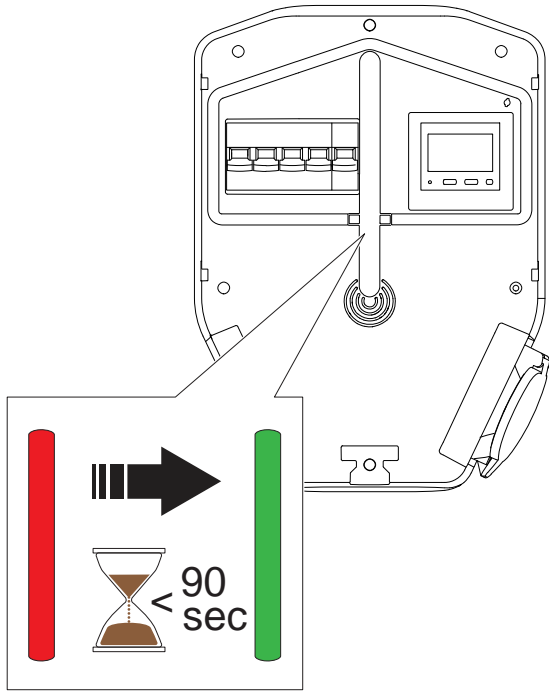

5. Set the charging station to state B (shown with a blue solid light indication).

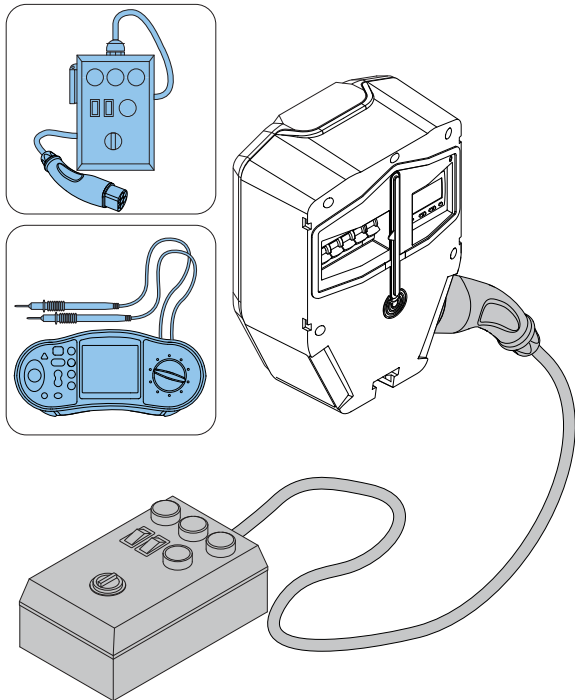

6. Set the charging station to state C. Shown with a blue pulsating light indication.
7. Do a check of the voltage in the Type 2 outlet.
8. Press the test button (T) on the charging unit for approximately 1 second but not more than 5

seconds. Make sure that the all-pole circuit breaker is triggered.

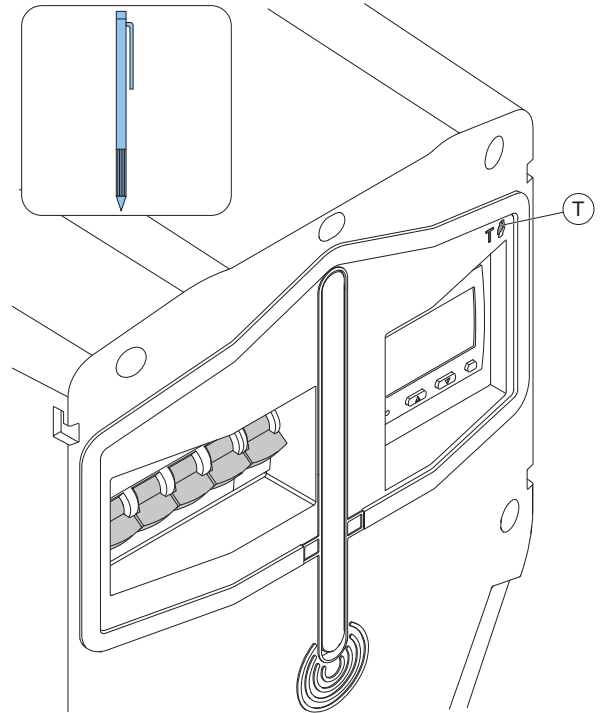

9. Reset the all-pole circuit breaker.
10. Do a test of the earth faults (AC and DC) with a test instrument.

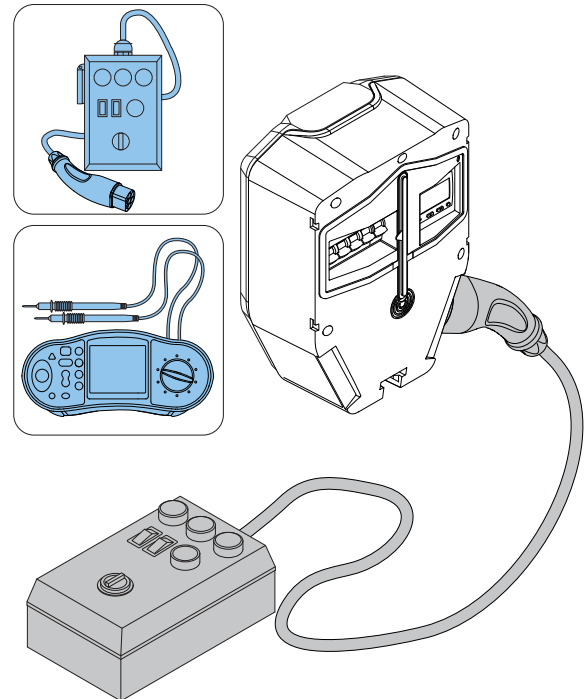

11. When needed, reset the all-pole circuit breaker.
12. Set the charging station to state A.

13. Disconnect the test equipment.

14. Test charging an EV.

4.12.16 TO MOUNT THE FRONT COVER OF THE CHARGING UNIT

1. Mount the front cover of the charging unit.

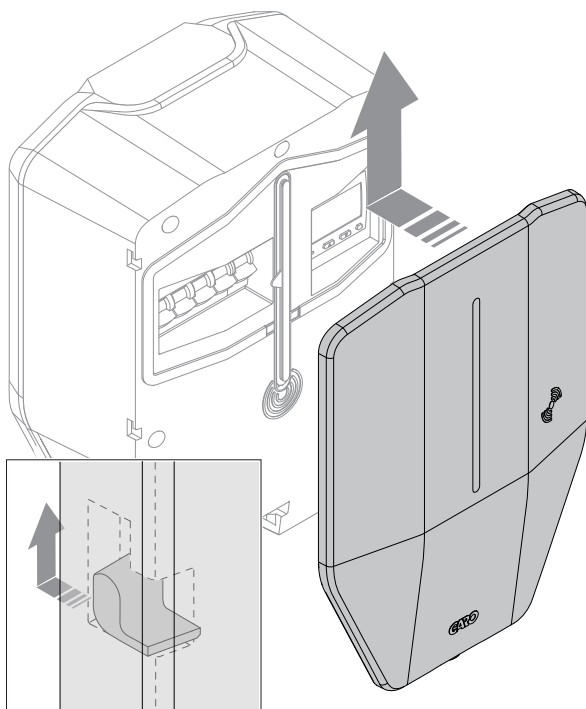

2. Lock the front cover at the bottom of the charging unit. The key can only be removed in locked position.

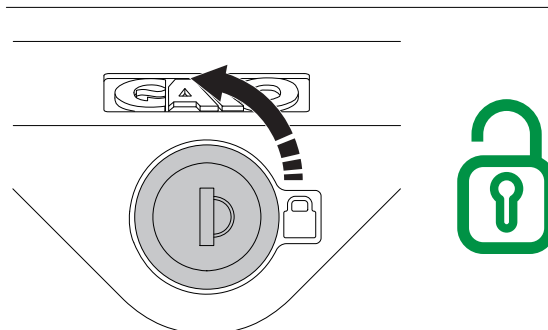
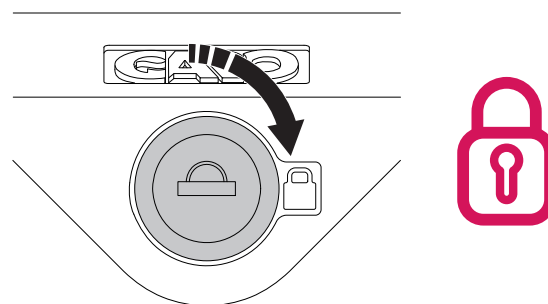

NOTE

The front cover is supplied with two keys. Both keys should be handed over to the owner of the charging station.

3. After the final testing, the installation of the charging station can be declared ready in the GARO Connect app, The charging station becomes available to use and visible to EV drivers with access rights.

NOTE

If the charging station is part of a connection group for DLM, then it is recommended to complete the whole installation of the connection group and to test it, before the installation is handed over to owner for operation.

4.13 DYNAMIC LOAD MANAGEMENT (DLM)

4.13.1 DYNAMIC LOAD MANAGEMENT (DLM) FUNCTIONALITY

Dynamic Load Management (DLM) is based on a grouping of loads that share a specific critical equipment, such as a fuse. Each connection group is based on one master device (charging station or load interface) in the connection group. The master device

should preferably be the connection point for internet, but this is not a requirement. Any unit of the group can be defined as internet gateway/communication master. The connection group is also defined by a maximum current, which is typically the same size as the fuse that is to be protected from overload.

The connection group either consists of either 1 or several charging station(s), where the real current is

calculated as the sum of all charging station currents, or several charging stations together with other loads. If the connection group consists of other loads as well, then the real current needs to be monitored, using a load interface. The load interface acts as DLM master of this connection group. The charging stations (and possible subgroups) will share the remaining current (unused fuse capacity) to prevent overload.

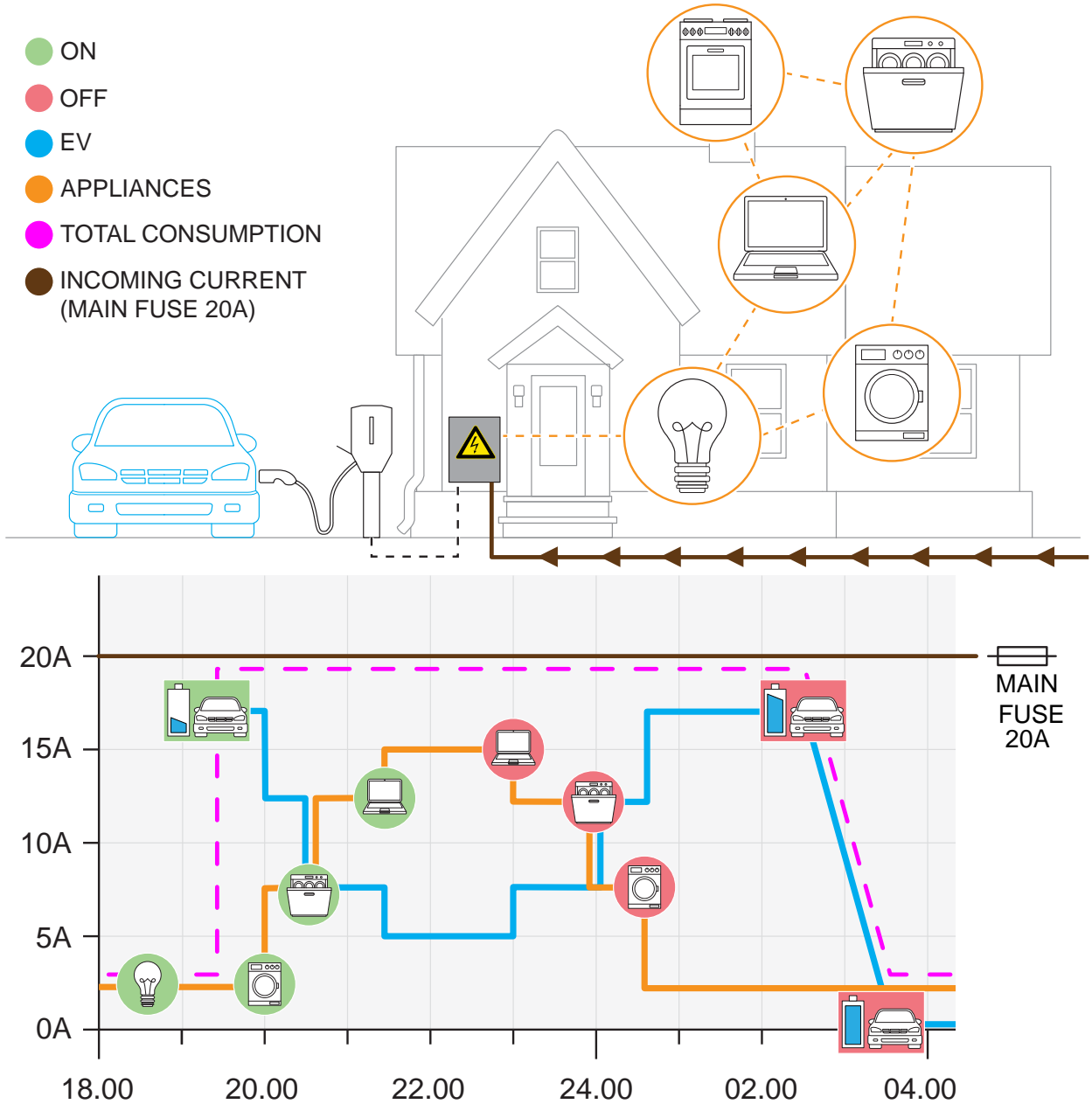

The real current is measured by current transformers or energy meter, and transferred into the system with a load interface. It is possible to define several connection groups as a hierarchy of maximum four levels.

NOTE

Internet connection is necessary for configuration but not for operation.

The load interface transfers current information to the DLM system by reading a current transformer or an energy meter, and act as master unit for DLM in the connection group. In that case, internet connection for access control is recommended to be done through the master load interface. The load interface can be connected to internet via Wi-Fi or ethernet. Refer to [4.13.3 To install the load interface in an electrical cabinet, page 50](#). It can also participate in a Wi-Fi Mesh network.

The load interface is necessary in most installations and all settings are done in the GARO Connect app. The communication platform is in the same network as the charging station(s).

NOTE

The load interface is available in two versions, GARO Entity Balance Basic and GARO Entity Balance Advanced. The difference lies in connectivity. GARO Entity Balance Basic should fit most installations. If the Utility meter contains HAN, then this is recommended to use.

If the group contains local production (like PV/solar panels) with a net output power that can get close to the max. current, then a separate energy meter for bidirectional power is required. Only current transformers are not capable to detect power direction.

Multi-Level Load Management

The GARO Entity system is prepared to work with the load interface, to support multi-level load management. This means that current limitations can be managed on several (up to 3) levels of the installation.

The first level could be a fuse, feeding a group of charging stations. If a connection group contains only charging stations, then no load interface is required, total current is calculated by adding the charging station currents.

The second level could be the fuse feeding the building where the charging stations are connected.

A third level could be the main fuses to the location.

Up to 4 levels are possible to configure with the app-based user interface. These settings are made by the installer.

By using the GARO Connect app, any limitation that occurs can be analyzed to see what causes the limitation.

NOTE

A unit (a load interface or charging station) can only have 1 master role. If a multi-level DLM only consists of only charging stations (no other loads), a load interface must be introduced on the second level to manage the superior group.

DLM Algorithm:

If the total current consumption exceeds the set limit, then the current consumption is limited to within the group and all charging station are allowed the same current. First 3-phase is allowed to all.

If 3-phase power is not available for minimum charging current of a charging station, but there is still current capacity on any single phase (1-phase), then charging can be continued on this/those individual phase(s) available on some single phase.

Some models of charging stations have a built-in phase management system, that can select the 1-phase system fully dynamically to select the correct phase(s).

If all current capacity is used up, and a new EV is trying to start, then the EV's will be served in that order they connected.

4.13.2 LOAD INTERFACE INSTALLATION OVERVIEW

GARO Entity Balance Basic

Functional grounding of CT's

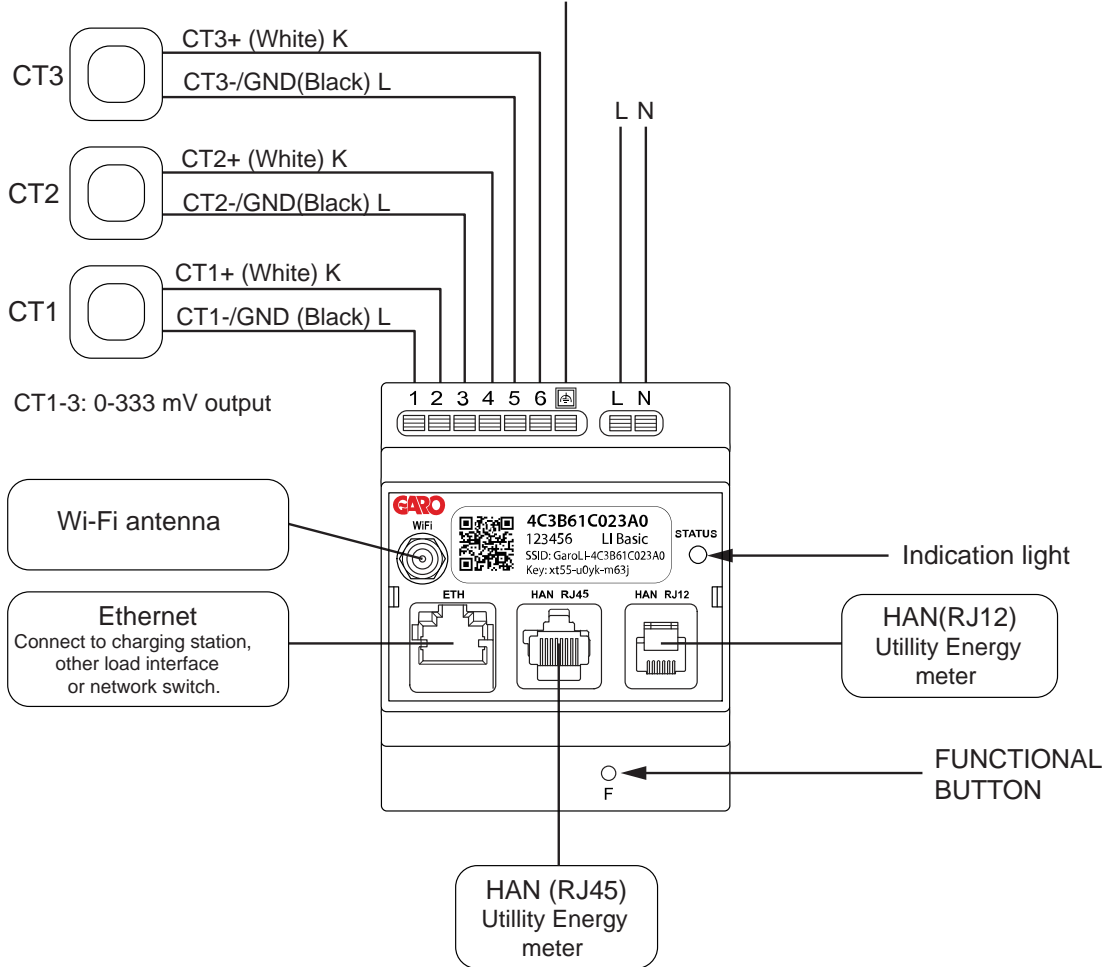

GARO Entity Balance Advanced

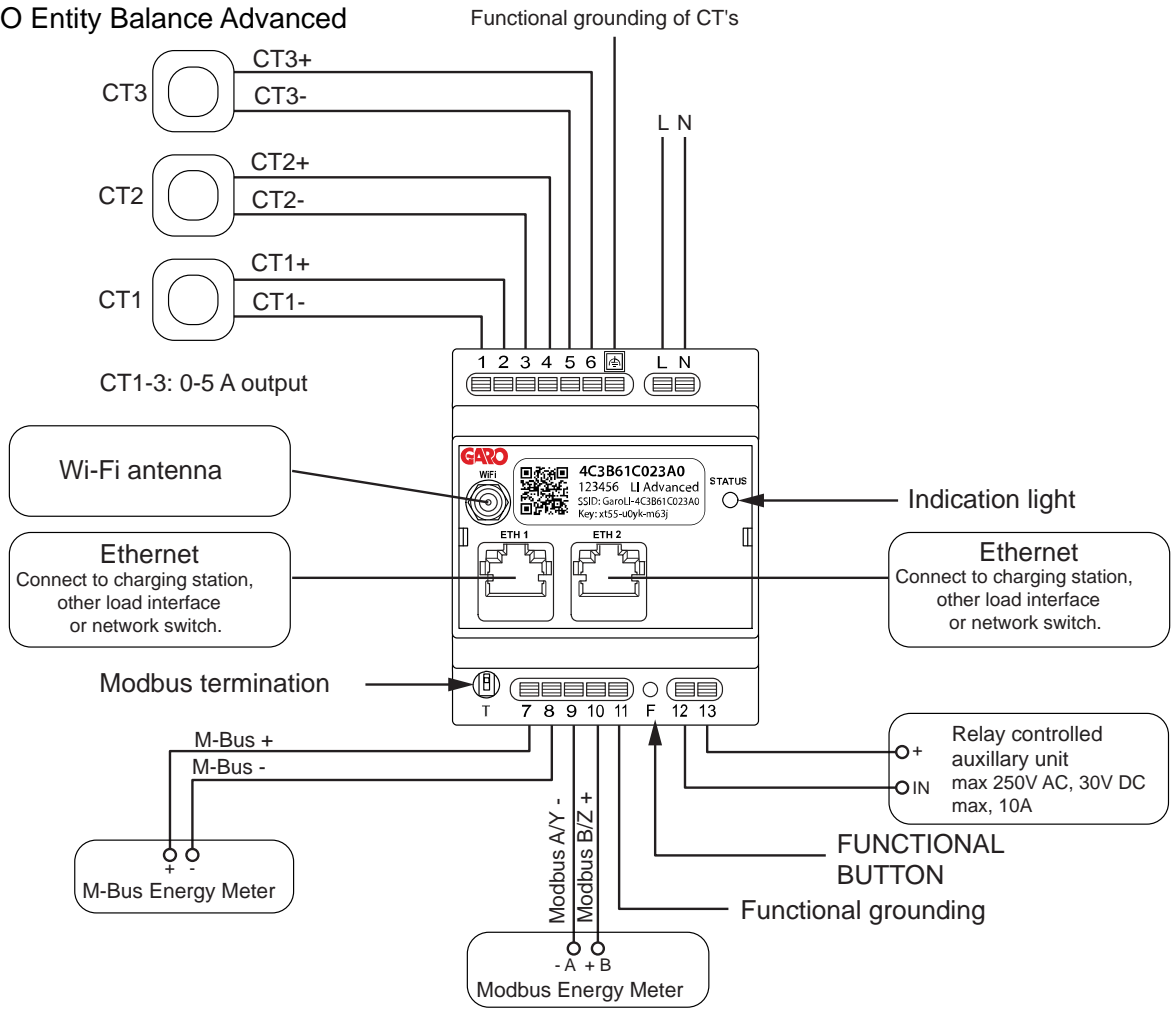

3-level Connection group (CG)
Power monitoring structure

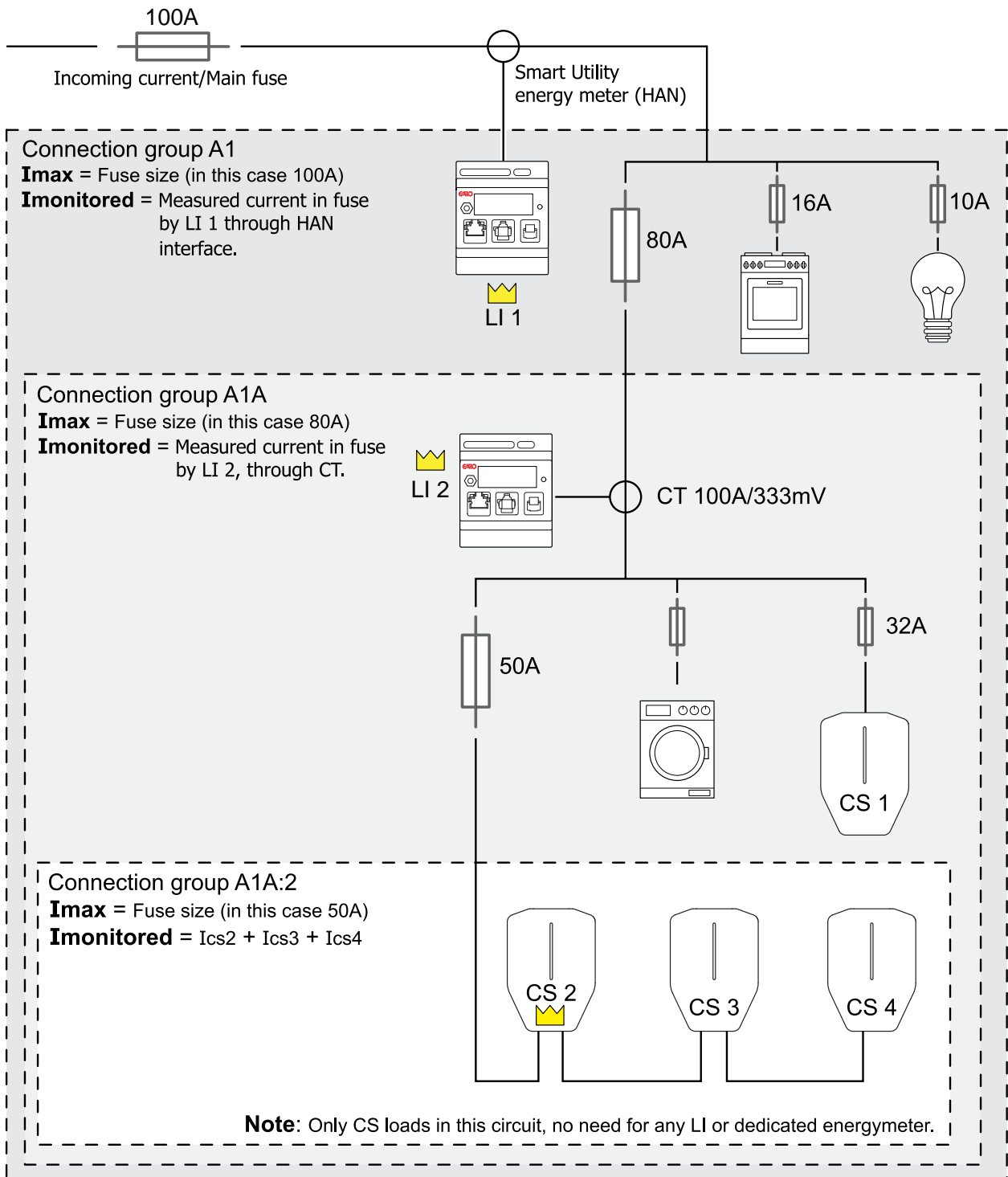

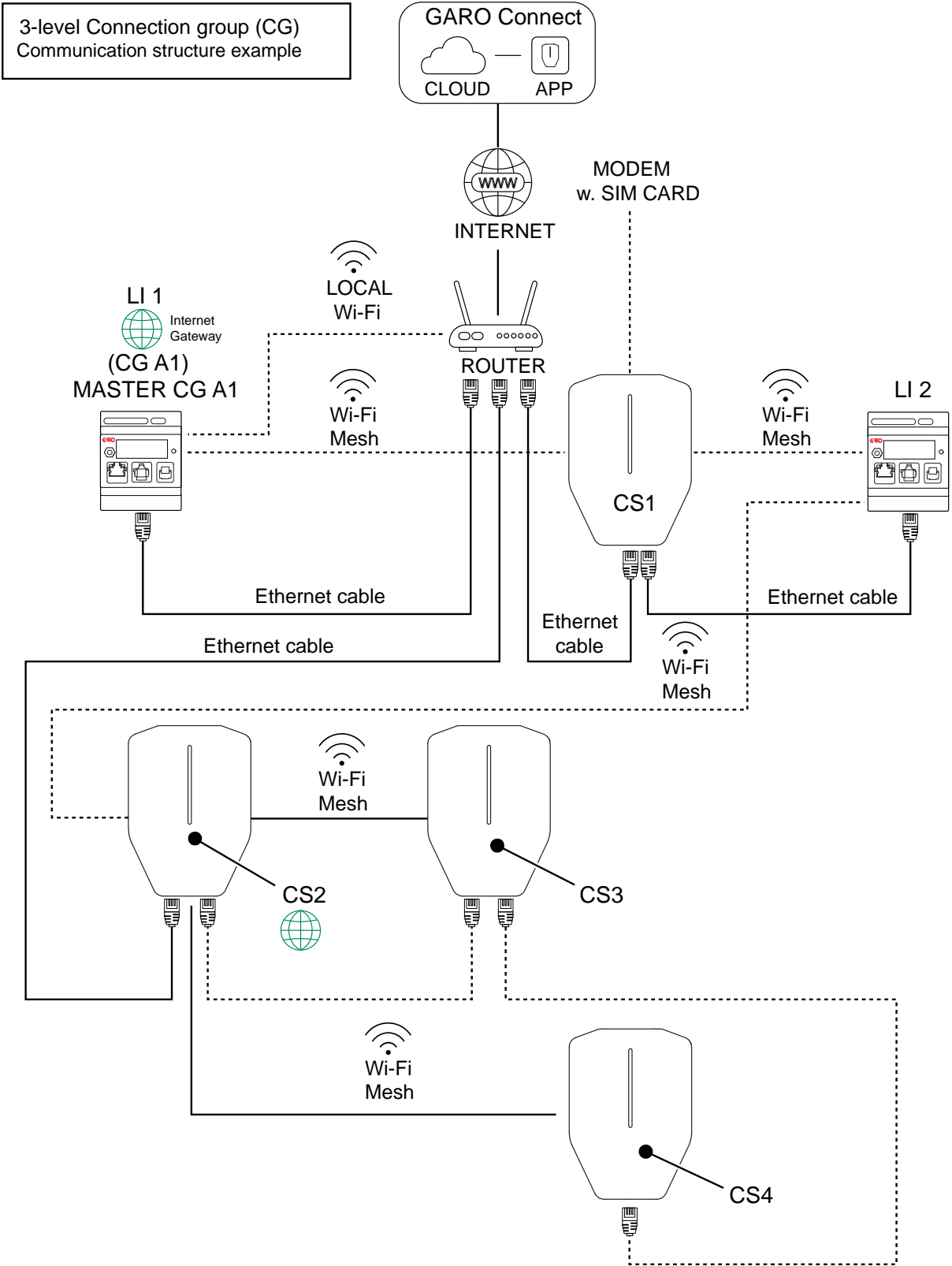

4.13.3 TO INSTALL THE LOAD INTERFACE IN AN ELECTRICAL CABINET

GARO Entity Balance Basic

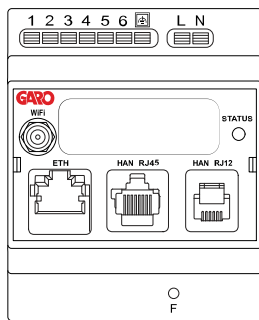

GARO Entity Balance Advanced

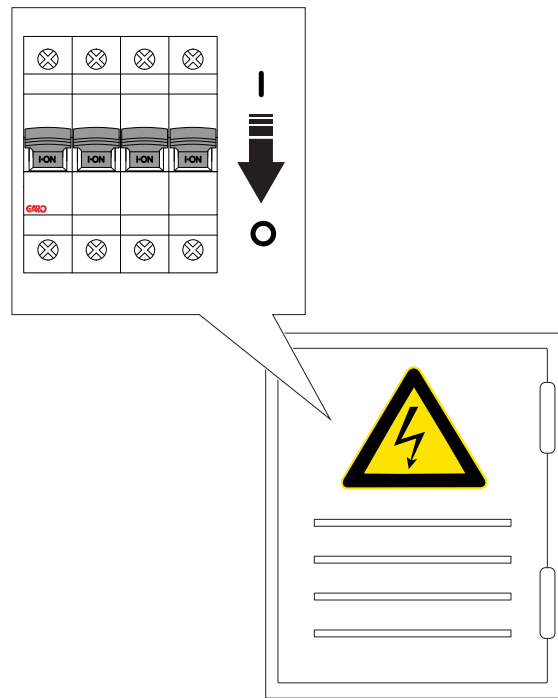
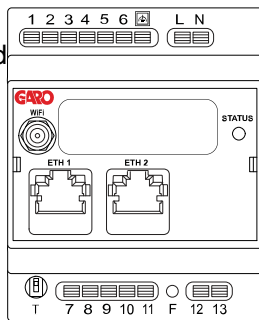

2. Make sure that the power/voltage is off.

This is a general instruction of the load interface installation. The load interface is intended to act as an interface to the power and current meters as input to the DLM system of GARO Entity charging stations. The procedure differs between different installations and can also differ due to national regulations. The load interface unit is designed for DIN rail mounting. Two different load interface units are available at GARO: GARO Entity Balance basic and GARO Entity Balance advanced.

NOTE

This chapter shows the installation of the GARO Entity Balance BASIC model. The process for the GARO Entity Balance ADVANCED is similar. If the group contains local production (like PV/solar panels) with a net output power that can get close to the max. current, then a separate energy meter for bidirectional power is required. Only current transformers (CT) are not capable to detect power direction.

1. Turn the power/voltage off by an appropriate insulating main switch.

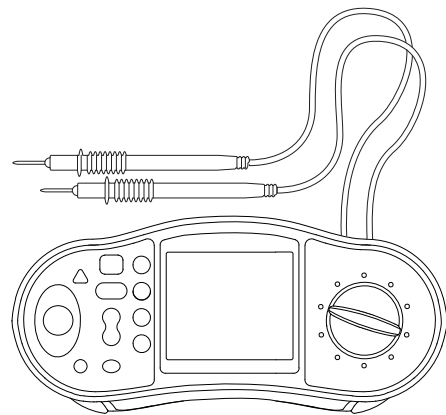

3. Install an insulating and protection device (RCBO or MCB) on a DIN rail (A). The load interface normally requires an individual insulating and protection device for 230 V. For this purpose it is recommended to use a 2-pole 2-10 A RCBO.

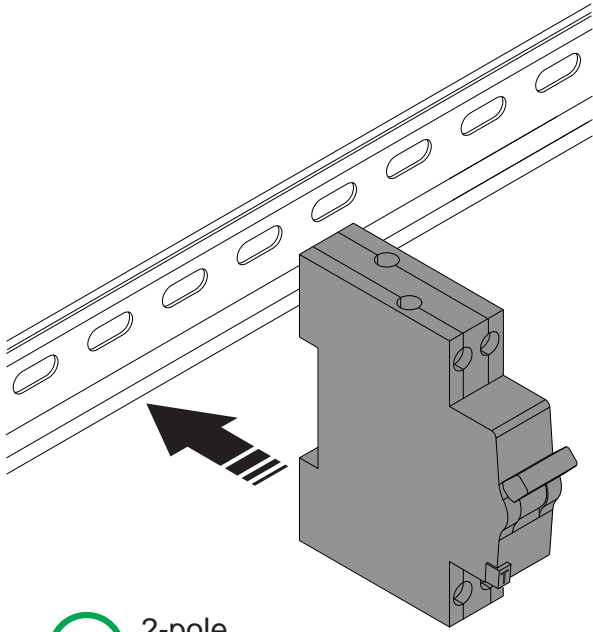

2-pole
2-10 A

4. Install the load interface unit (C) on the DIN rail.

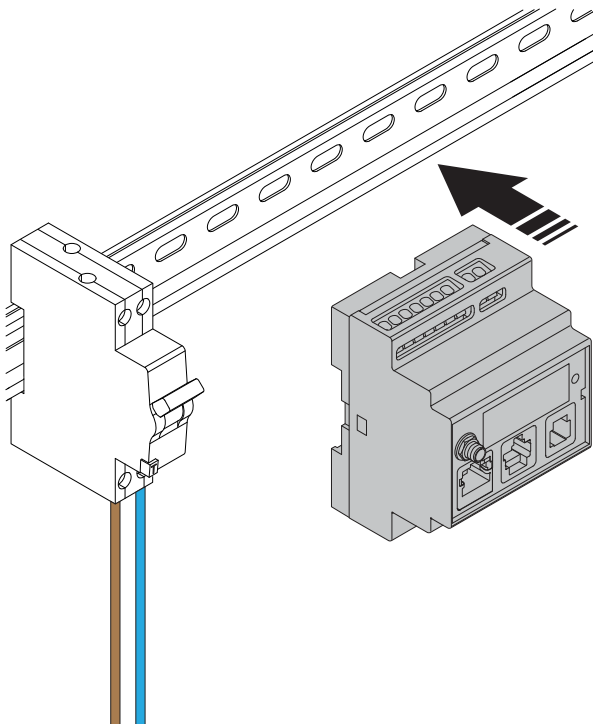

5. Dismantle the wires and connect the load interface to the 230V AC. Refer to the electrical schedule for all electrical connections.

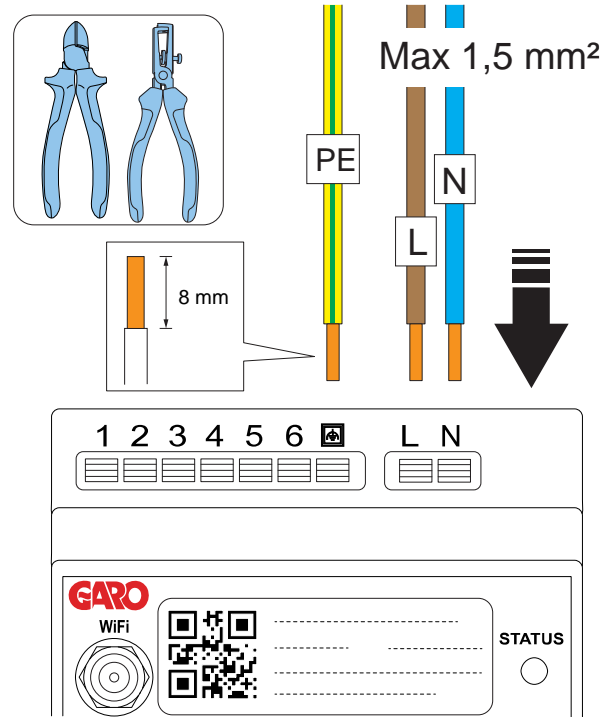

6. Connect the load interface to the protection device.

NOTE

Functional Ground connection (here shown as PE) is only recommended to use when connecting current transformers. However, it may also contribute to Wi-Fi performance, since antenna groundplane is enhanced.

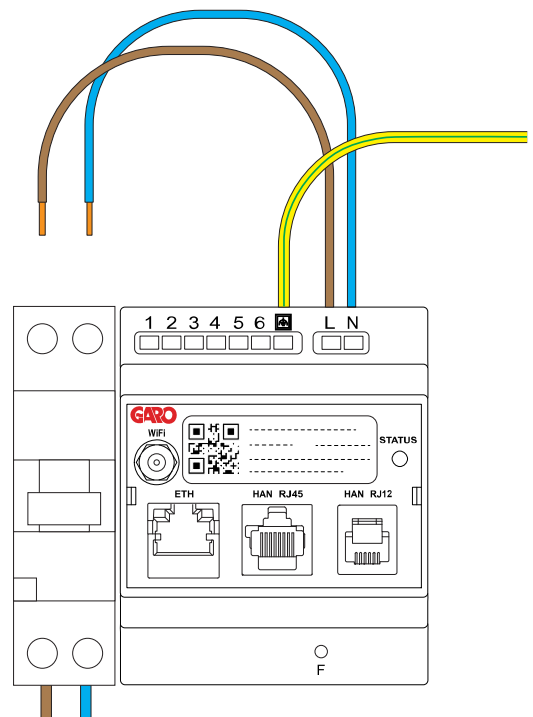

- If current is measured using current transformer, choose the correct current transformer (CT) for the installation.

WARNING

Make sure that you choose a current transformer (CT) that is suitable for your installation. Current transformers of 2 output types can be used. 0-333 mV or 0 – 5 A output range. For easy installation, GARO recommends the 0-333 mV type when possible.

0–333 mV is only valid for GARO Entity Balance basic and 0–5 A is only valid for GARO Entity Balance **ADVANCED**. Take notice: 0-5 A output types of current transformer clamps must never be exposed to open circuit conditions.

NOTE

This chapter shows the installation of the GARO Entity Balance basic and the GARO 0-333 mV CT clamps that are available as accessory. The process for the GARO Entity Balance advanced is similar.

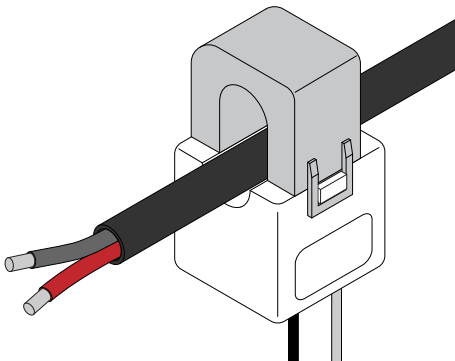
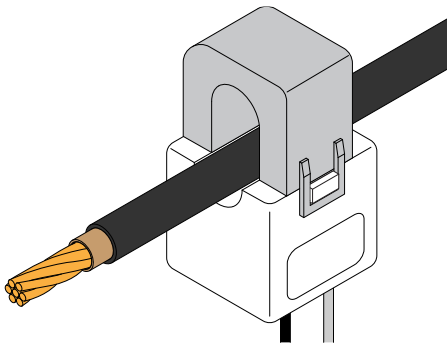

- Dismantle the current transformer wires and connect the current transformer clamps to the load interface.

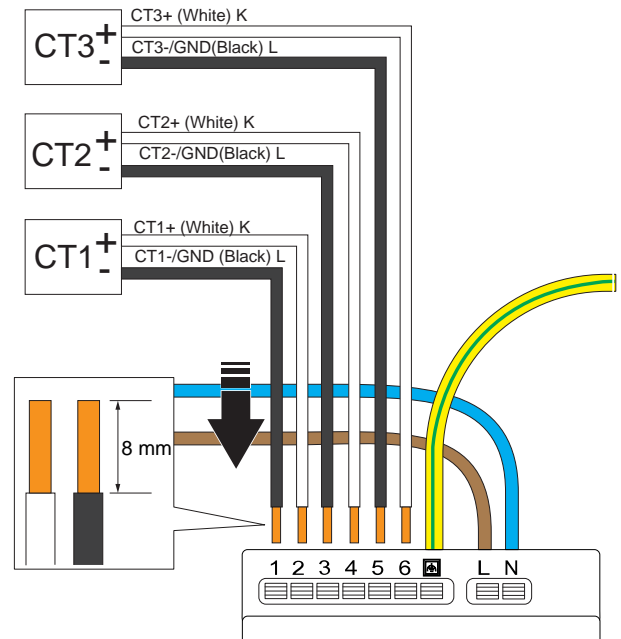

CT1-3: 0-333 mV (Basic)
 CT1-3: 0-5 A (Advanced)

Use a wire ferrule (A) for strained wires (B).

NOTE

The functional grounding connector next to the PE conductor is internally connected to one of each current transformer pole (no. 1, 3, 5). This in order to provide a defined voltage potential. It is recommended that the functional grounding conductor is connected to a ground potential, such as the PE conductor.

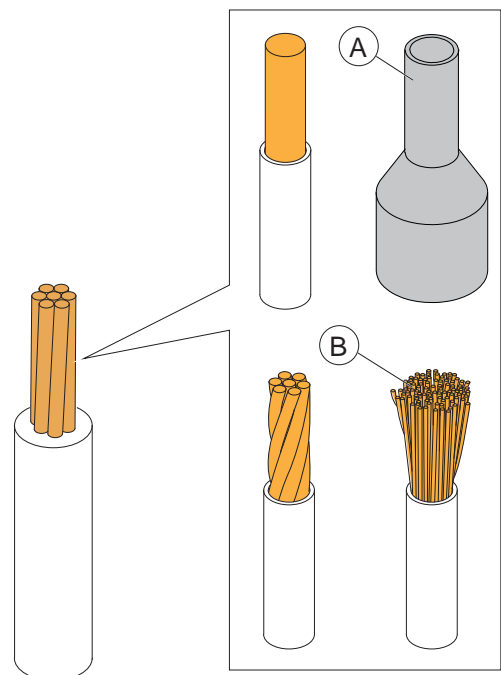

The input terminals 1, 3 and 5 are internally connected to PE in the load interface.

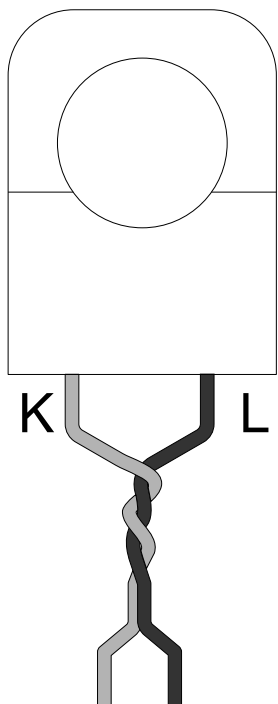

Wires -L are recommended to be light-twisted as pairs, to reduce induced disturbances.

- Attach the current transformer clamps to the measured current.

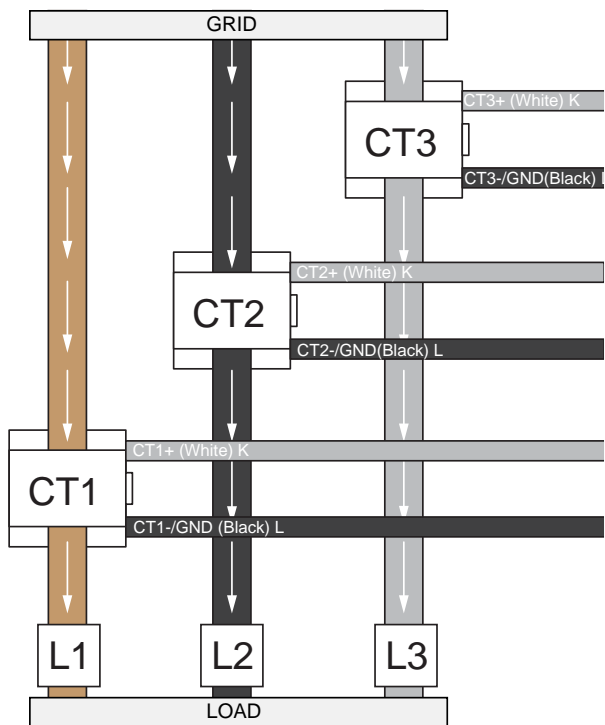

- Make sure that the metal contact surfaces are really clean before closing the current transformer (CT)

clamps. Close the current transformer (CT) clamp. A click is heard when it locks.

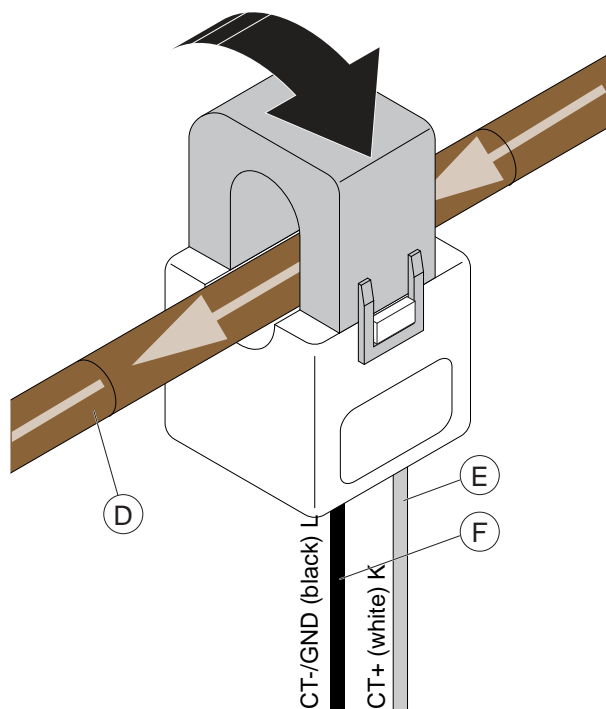

CAUTION

Note the current direction of the cable (D) and the position of the positive (K) and negative (L) cable of the current transformer (CT) clamp.

- The GARO Entity Balance BASIC is prepared for HAN communications to the modern main utility meters, based on RJ12 or RJ45 connections. HAN is only available on GARO Entity Balance basic.

NOTE

HAN:

Several grid utility companies require an owner to formally order an activation of the HAN-port. To establish what applies for a specific location, contact applicable grid utility company.

The HAN utility energy meter must also have an integrated 5VDC source in the HAN RJ12 connector. Not all HAN-meters are equipped with an integrated 5VDC source in the HAN RJ12 connector. If the HAN-meter is without a 5VDC source, an active adapter can be used instead. If other components/receivers need to use the RJ12 HAN port, use a passive "Y-splitter".

12. Also, the energy meters can be used as traditional energy meters: Apart from the HAN utility energy meter, traditional energy meters based on M-bus or Modbus can be used also by advanced version. To use the traditional energy meters it is necessary to make sure that the communication parameters match in the settings in the GARO Connect app vs. the energy meter.

NOTE

A load interface can be used in systems with local production (PV/solar inverters or battery systems). In such a case, it is important to keep track on the power direction. This can only be performed using a dual-direction capable energy meter. Current transformers on their own cannot provide that information.

13. The load Interface is a part of the total GARO Entity charging station communication network, that could be based on either ethernet cable, Wi-Fi mesh or a Wi-Fi that is part of an existing IT infrastructure. The GARO Entity Balance basic has 1 RJ-45 Ethernet port. The GARO Entity Balance advanced has 2 RJ-45 Ethernet ports.

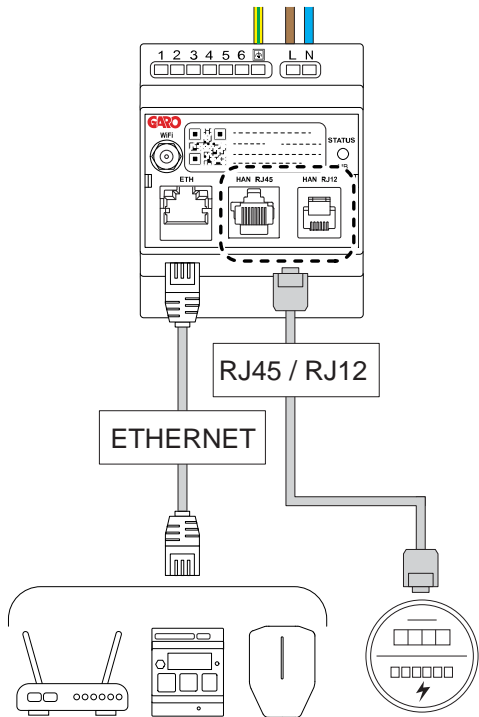

14. It is always recommended to connect an antenna even if a Wi-Fi or a mesh Wi-Fi is not used.

15. The short external antenna is supplied with the product. Use this antenna if the distance to the charging station is short. There are several factors that can lower the range of the antenna (i.e. obstacles, metal cabinet, other radio equipment, etc.).

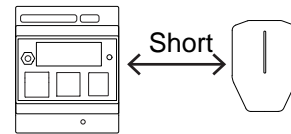
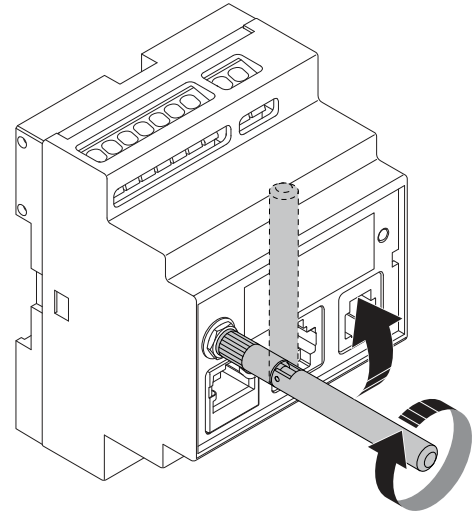

16. A long range, panel-mounted, circular disc Wi-Fi antenna is available as accessory at GARO. It is used when the distance to the Wi-Fi or mesh Wi-Fi node (= other entity unit) is long or obstacles can occur. Assembly instructions are supplied with the external antenna. If the load interface is mounted inside a metal cabinet, it is highly recommended to use the external disc antenna.

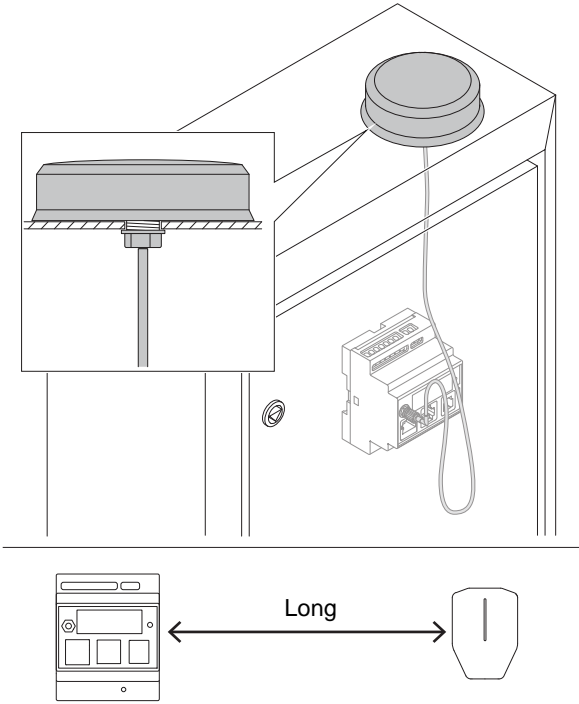

17. Turn the power/voltage on.

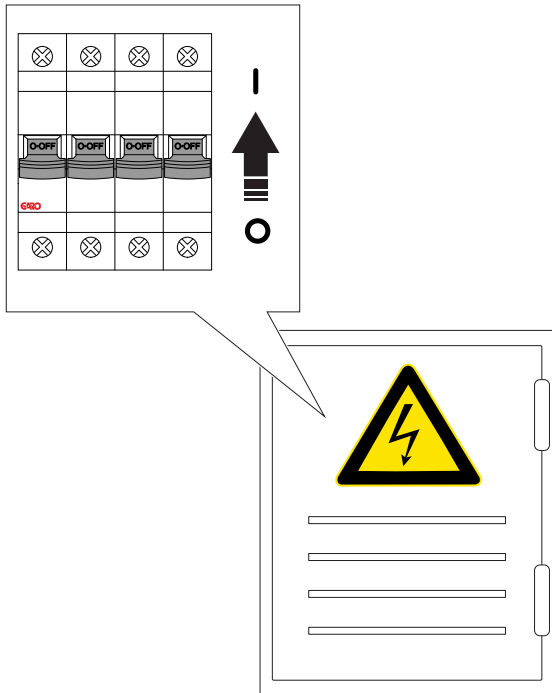

18. The light indicator on the front panel turns red at power/voltage up. Make sure that the indicator light on the load interface turns green. This can take 60–90 seconds.

The last few seconds before turning green, the light turns blue. This is to indicate that the firmware starts

operating correctly. However, the most important step is the green light.

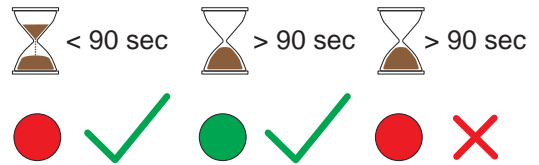
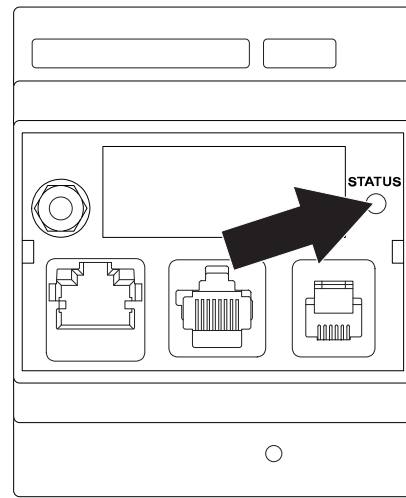

NOTE

If the light indicator on the power unit does not turn green within 90 seconds of powering up the power unit, refer to [7.1 Troubleshooting, page 93](#).

19. Download the GARO Connect app on AppStore or Google Play store.



20. Configure the settings in the GARO Connect app.
Scan the QR code on the load interface.

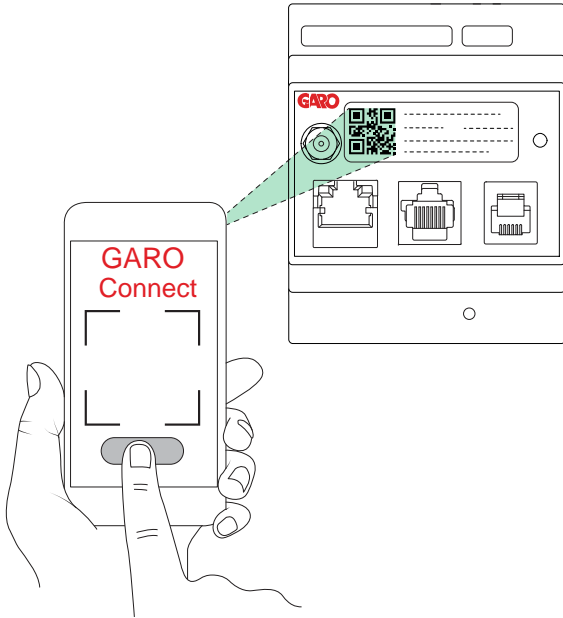

21. Test the load management setup to ensure that the current is limited at high load conditions.

Testing the DLM:

The first step is always to verify that the measured DLM current is correct. Check the energy meter or other current meter.

Testing a DLM system can be challenging. A small installation at a private home, with 1 charging station and 1 load interface is usually easy to verify. An example is charging an EV while using heavy electric consumer equipment in the house (the stove, water heaters). Larger sites are more complex to verify and may require many EVs. A possibility is to temporarily adjust the DLM limit current down to a level that is more "possible" to affect by whatever loads that can be used.

4.14 GARO CONNECT

4.14.1 THE GARO CONNECT APP

The GARO connect app is to be used for the installation, management and operation of the GARO

Entity charging station. The instructions in this manual are intended as an overview of the setup and functions of the GARO Connect app.

The GARO Connect app can be downloaded from Google Play or App store on a digital device. Register as a new user in the GARO Connect app. Use an e-mail address as username.

4.14.2 GARO CONNECT APP PROCESS OVERVIEW

The GARO Connect app is based on a standard/ startup process for both the owner of the charging



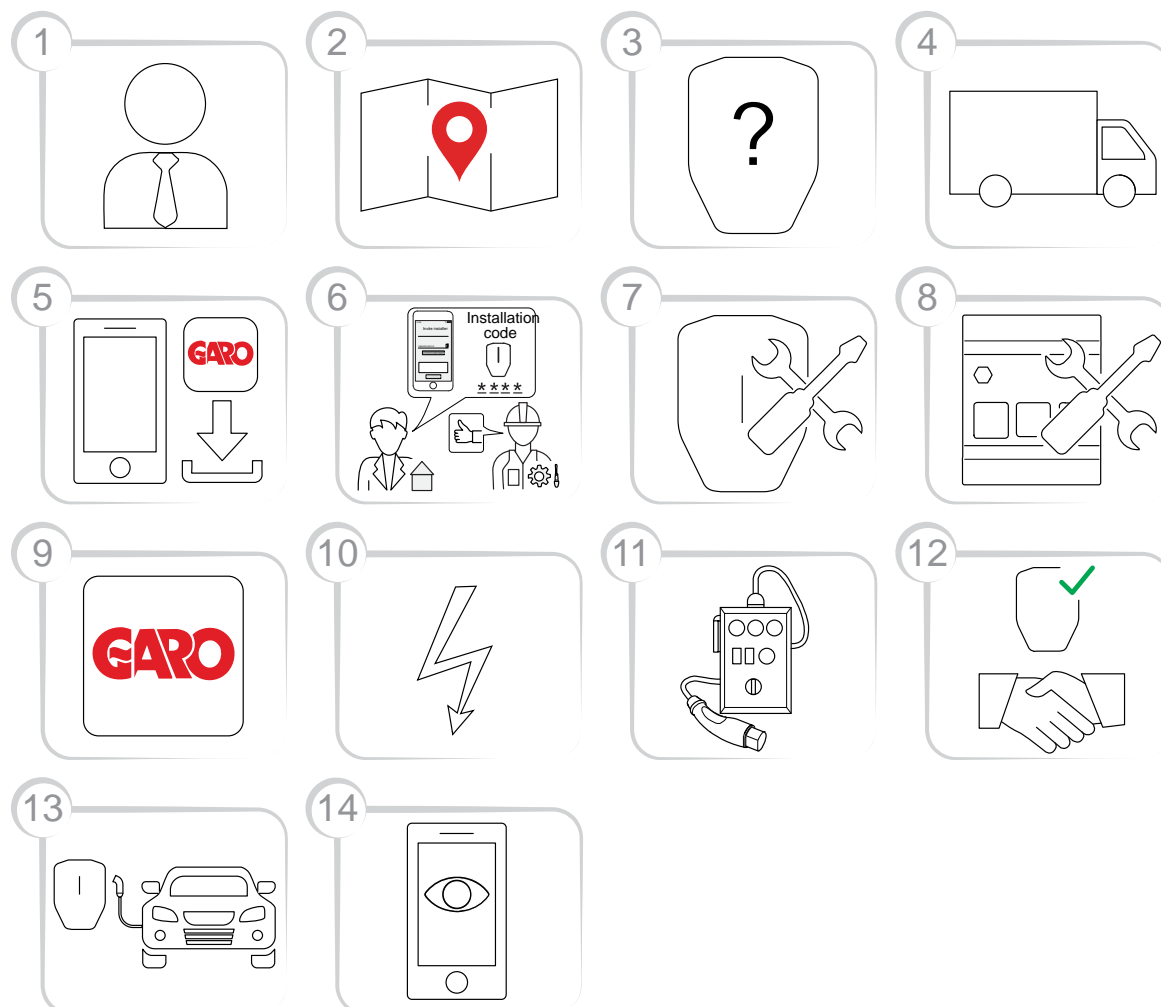





station, and the installer of the charging station. The illustration shows the process from both perspectives.













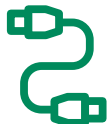





1. Owner (or installer): Consult a GARO representative for correct choice of product variant.
2. Owner: Prepare the installation and choose location.
3. Owner (or installer): Choose product(s) and accessories.
4. Owner (or installer): Receive delivery of product(s) and accessories.
5. Owner and installer: Download the GARO Connect app.
6. Owner (or installer on behalf of the owner): Prepare the installation and invite the installer.
7. Installer: Install the charging stations(s) (CS(s)).
8. Installer: Install the load interface(s) (LI).
9. Installer: Follow the installation guide in the administrative tool - the GARO Connect app.
10. Installer: Apply power/voltage to the charging station.
11. Installer: Perform a test of the installation.
12. Installer and owner: Declare installation as complete in the GARO Connect app. Do the handover to the owner.
13. Owner and/or EV driver: Charge an EV.

14. Owner: Manage access control for EV drivers, monitor the system, refer to [To prepare the installation \(owner\)](#), page 61.

4.14.3 GARO CONNECT APP SYMBOLS OVERVIEW

Icon	Icon name	Icon information
	Location	Click the icon to access the list of available locations.
	Chosen location	The icon is shown beside the selected location.
	Edit	Click the icon to make changes to the settings.
	Charging station	The icon is the symbol for charging station.
	Settings	Click the icon to adjust the settings of the product.
	Add	Click the icon to add a location, group, charging station, etcetera.
	DLM Master	The icon is shown beside the master charging station or load interface. If a connection group is set up without load interface, the master charging station is also acting a the DLM master.
	Communication master	The icon appears beside the master charging station or load interface that acts as a gateway to the internet or acting as master/starting point of a mesh Wi-Fi group.

	No internet	The icon informs that there is no internet. The master charging station must have internet access via modem, Wi-Fi, or an ethernet.
	Internet connection active via Wi-Fi	The icon informs that a radio based internet connection link is active and working. The icon also informs that the internet connection is available direct (to the internet connectivity master) or indirect to a non-master unit through a functional interconnection. The master charging station must have internet access via modem, Wi-Fi, or an ethernet cable.
	Internet connection active via ethernet cable	The icon informs that a internet connection link via an ethernet cable is active and working (working=green). The icon also informs that the internet connection is available direct (to the internet connectivity master) or indirect to a non-master unit through a functional interconnection. The master unit must have internet access via modem, Wi-Fi, or an ethernet cable.
	Complete	The icon shows that the installation is complete.
	Continue	Click the icon to continue the installation process.
	User manual	Click the icon to access the operator and installation manual of the product.
	Main menu	Click the icon to choose action in the main menu; load and use, manage charging stations and users, or install charging stations.
	Personal settings	Manage name and e-mail address. Click the settings icon next to your name to manage personal settings, such as name and e-mail address.

	<p>Installer tool</p>	<p>The Installer symbol is shown when using the installer pages of the app.</p>
	<p>RFID tags</p>	<p>Click the icon to add or remove RFID tags.</p>
	<p>User rights</p>	<p>Click the icon to manage settings for user rights.</p>
	<p>Password</p>	<p>Click the icon to change password.</p>
	<p>Favorite</p>	<p>Click the icon to mark the location as a favorite.</p>
	<p>Charging cable type 2</p>	<p>The icon is for the charging cable Type 2 that is connected to the charging station. This means that the charging station has a fixed cable. Only possible for GARO Entity CS.</p>
	<p>Type 2 outlet</p>	<p>The icon is for the Type 2 outlet, which can be used to charge the EV.</p>
	<p>Grid</p>	<p>A grid used to visualize the grid level of powerflow in the charging station (CS) status.</p>

4.14.4 OWNER

The owner is the person who owns one or several charging stations and the location, refer to [1.2.2 Definitions, page 5](#). The owner invites the installer to do all or part of the installation of the charging station(s). For more information about the installation process of the installer, refer to [4.14.5 Installer, page 68](#).

The installation process of the owner is described in the illustration below. For a full instruction, refer to [To prepare the installation \(owner\), page 61](#).

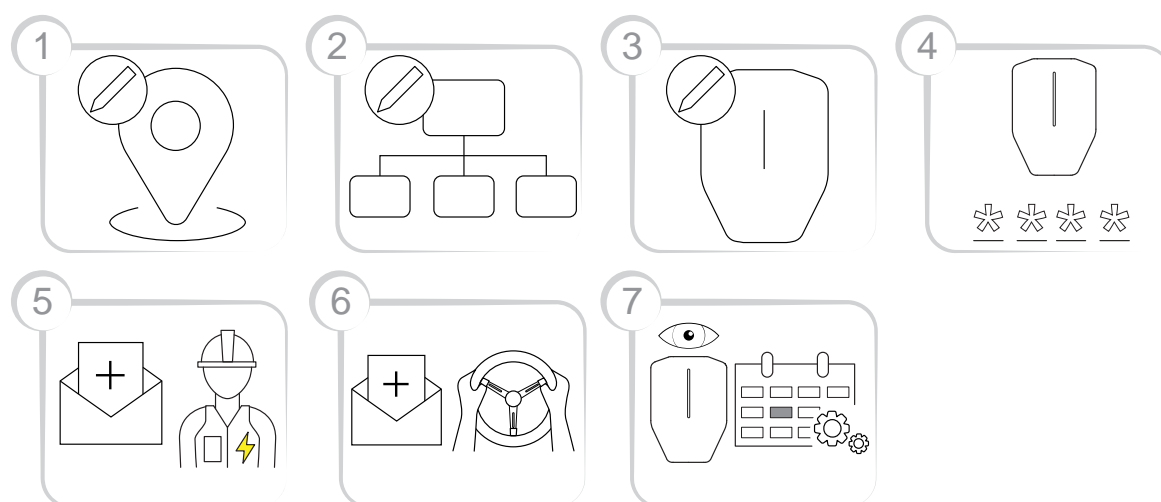

1. Create or choose a location. The “home” location is the default location.
2. Create an organization if it is needed. This is not mandatory for every installation. Add more persons as owners.
3. Create the logical charging station(s) (CS) in the GARO Connect app. The logical charging station(s) (CS) is later tied to a physical charging station (CS) by the Installer by scanning the installation bracket.
4. Generate an installation code.
5. Invite an installer to install the product(s).
6. Invite EV drivers and manage EV driver access control if needed. This is not mandatory for every installation.
7. Monitor the system of charging station(s) (CS). Ensure maintenance routines are followed. Refer to [6 Maintenance, page 89](#).

NOTE

A new installation (a location with charging station(s)) can also be set up by the installer, who can act as a temporary owner. After installation, the installer can transfer the location, that is the complete control of the product(s) to the owner.

To prepare the installation (owner)

NOTE

These instructions are for the owner. To see the whole process overview of the GARO Connect app, refer to [4.14.2 GARO Connect app process overview, page 57](#). To see the overview of the symbols and buttons in the GARO Connect app, refer to [4.14.3 GARO Connect app symbols overview, page 58](#).

1. Download the GARO Connect app.

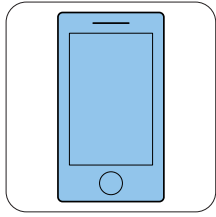

2. Create a new account in the GARO Connect app. Follow the instructions on the screen.
3. Log on to the GARO Connect app with provided credentials.

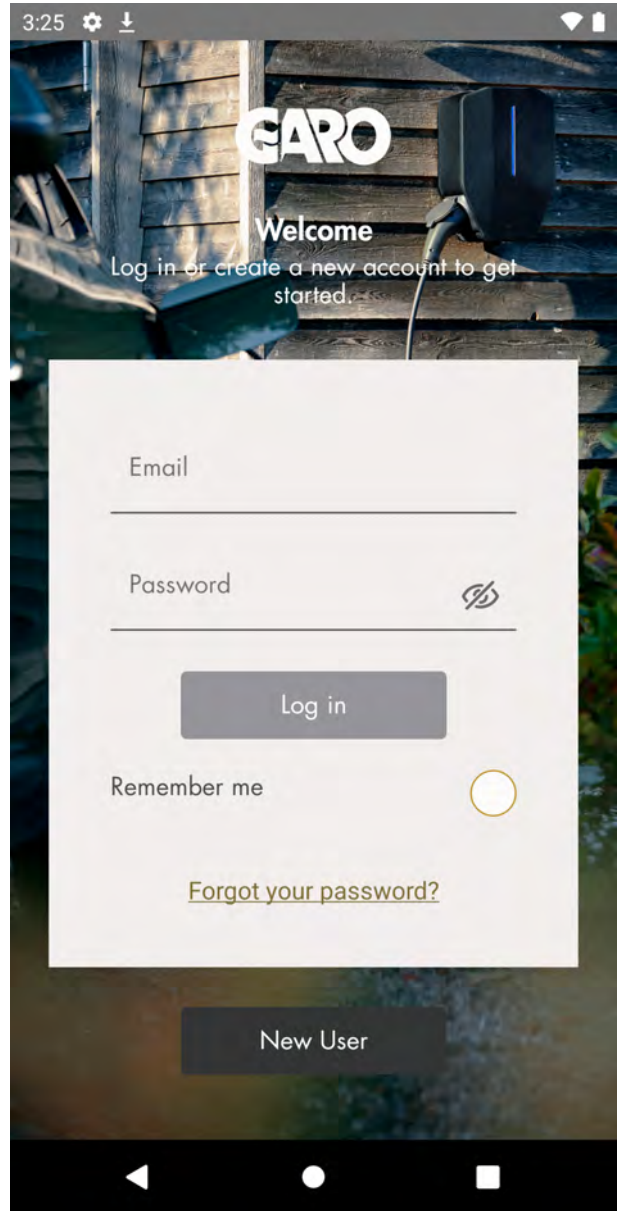

4. Select *Manage Locations*.

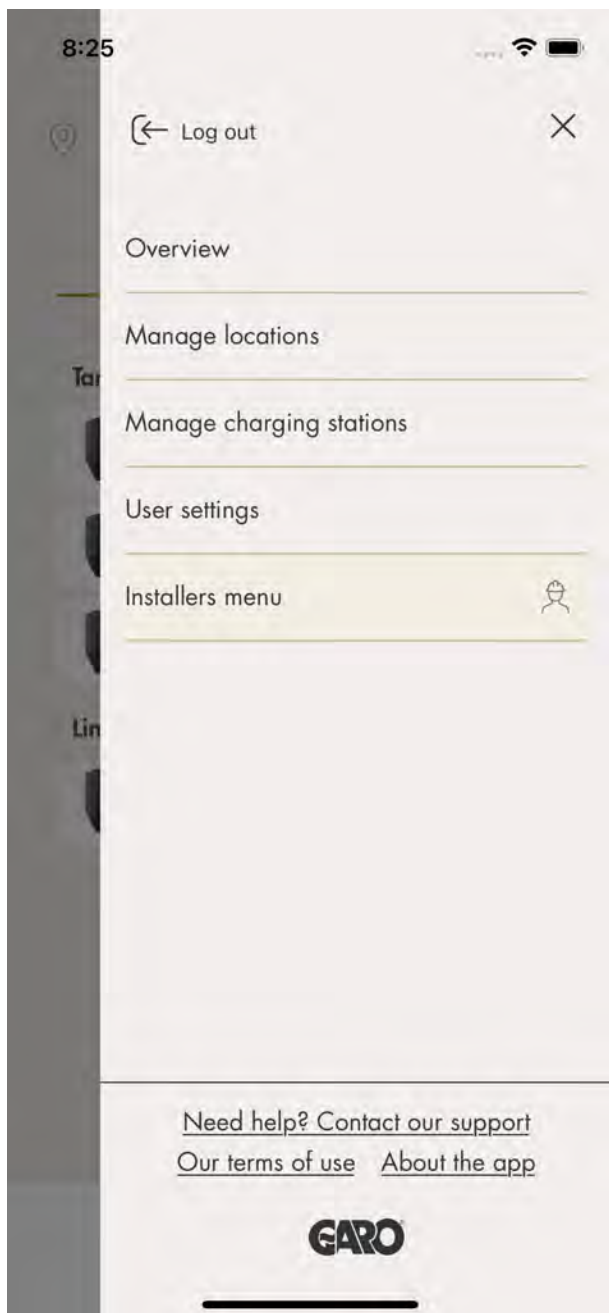

5. Choose location.

NOTE

It is recommended to change name on the default location. Preferably, the name should specify the physical place of the unit, including address and coordinates. In this example, the location is called *Main office*. To change the name of a location, click the location and choose *Edit location*.

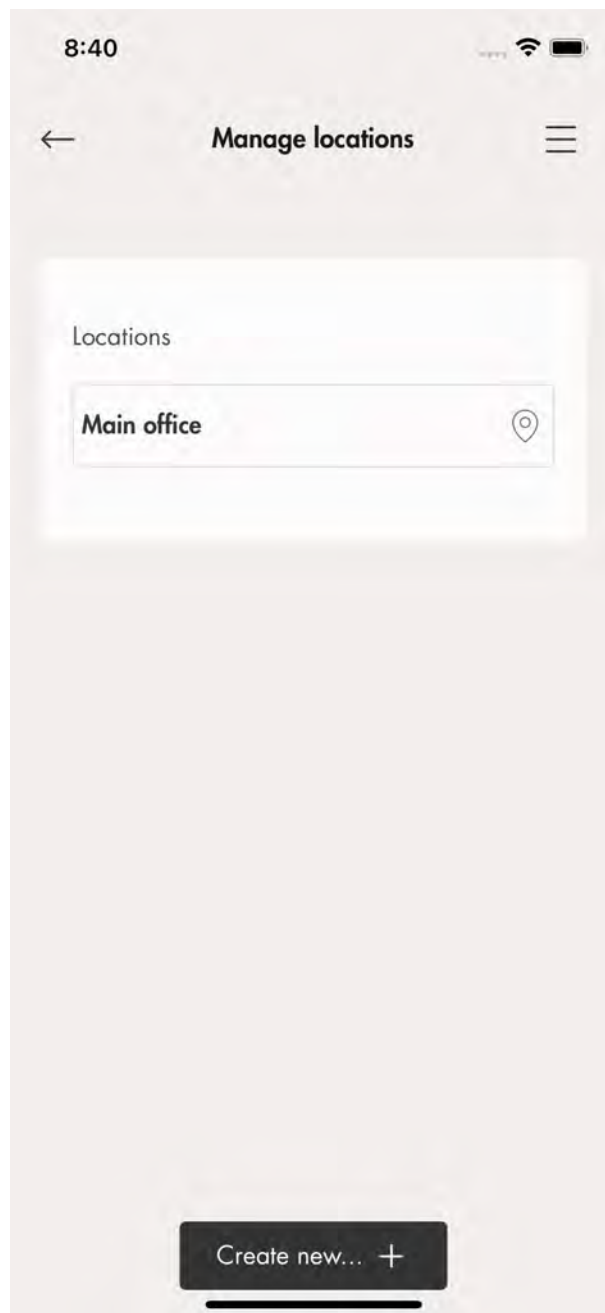

6. Select *Invite Installer*.

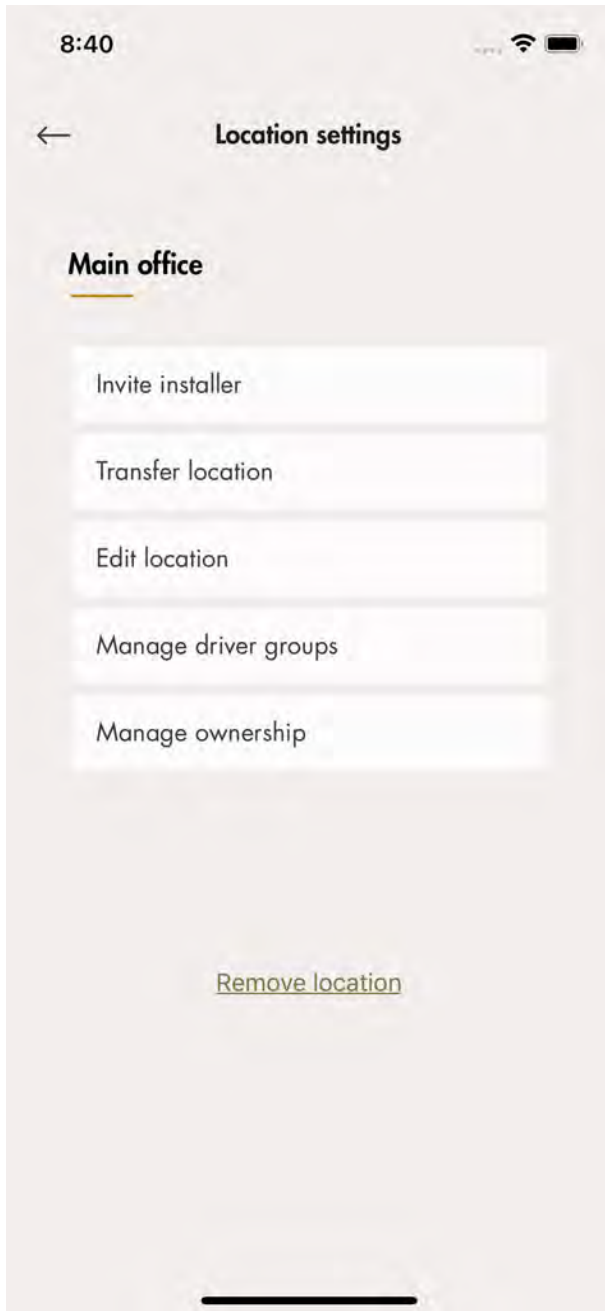

NOTE

The installer can create and install charging stations once invited with the installation code from the owner.

7. Generate an installation code. An e-mail can be generated to the installer through the GARO Connect app. This is not mandatory, any communication channel is fine.

A message to the installer concerning the location or installation can be tied to the location, for example the Wi-Fi credentials if a local Wi-Fi is to be used.

Charger settings

The features available under *Charger settings (owner)* are not mandatory.

- Charger settings

The settings for each charging station can be changed. Click on applicable charging station, then *Charger Settings* and follow the instructions in the app.

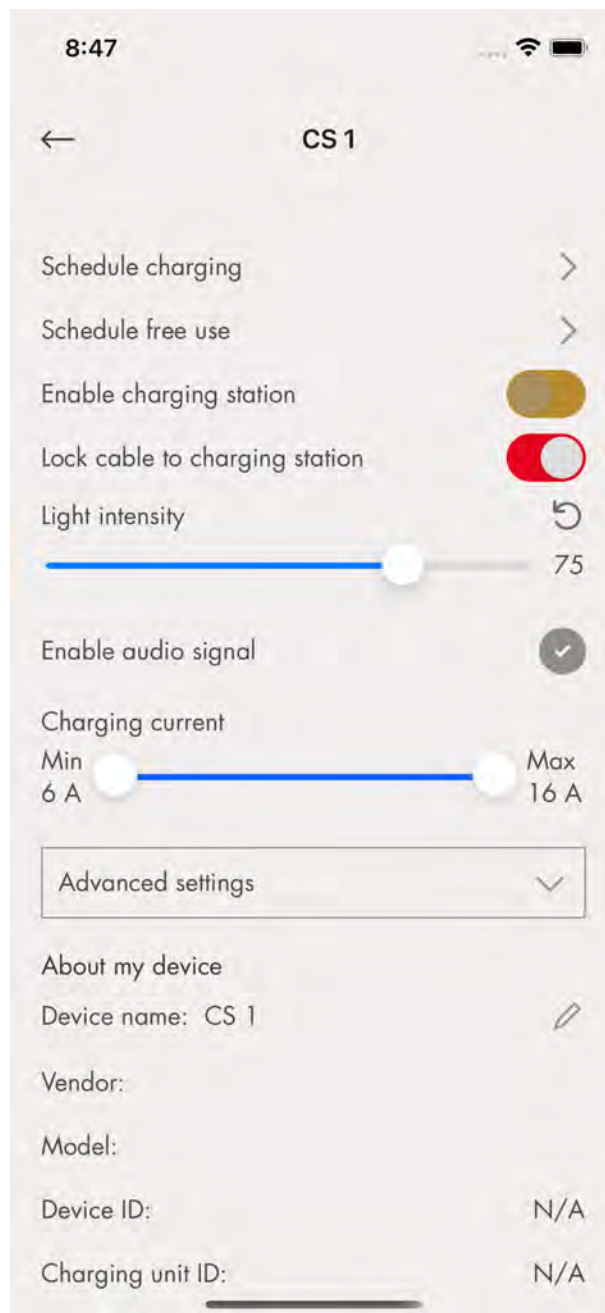
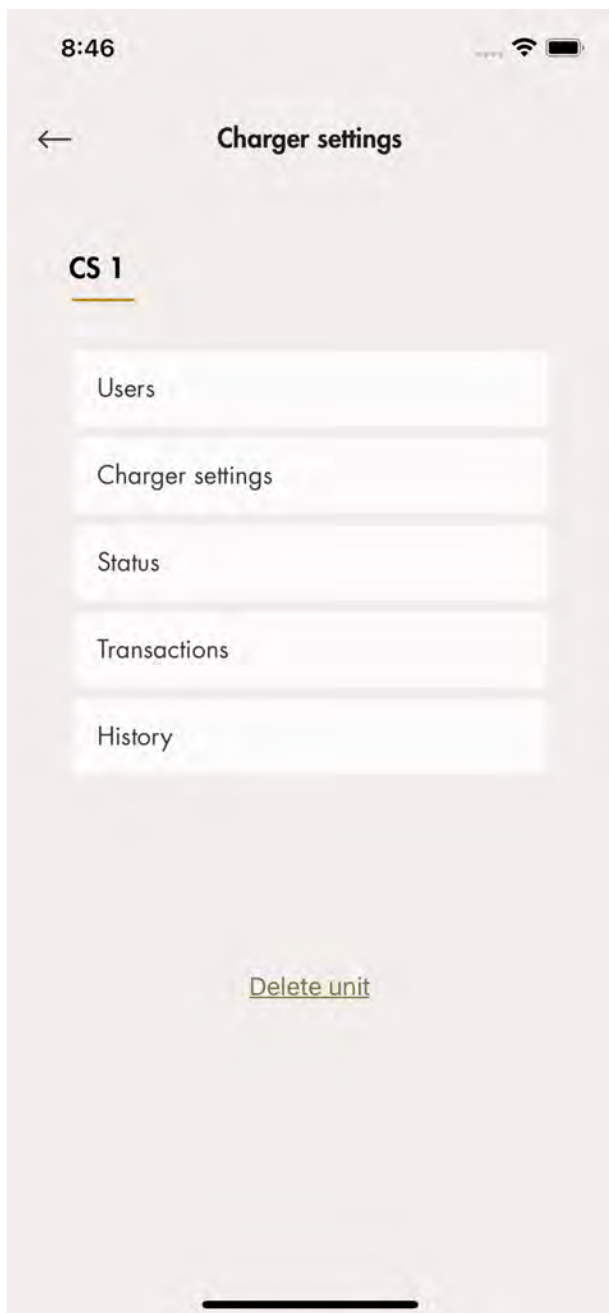

- Enable charging station

Under *Manage charging stations > Charging Settings*, each charging station can be enabled/disabled by the owner. If the charging station is disabled, the charging station cannot be used.

- Charging station access

Each charging station can be set to free use (default). This enables access for everybody. If the EV driver identifies before connecting to the EV, the charging transaction is registered to the EV driver.

At delivery the free use is enabled by default. The charging station is at that time not set up for access control. Free use can be used, even if the charging station has defined EV drivers, those rights can be seen as "overridden" by the free use.

- Invite drivers

The owner can invite EV drivers from the app. Click *Charger Settings*, select *Users* and follow the instructions in the GARO Connect app. EV drivers can be added individually or through an EV driver group.

NOTE

If the EV driver does not have a GARO Connect account, an invitation email will be sent to that EV driver.

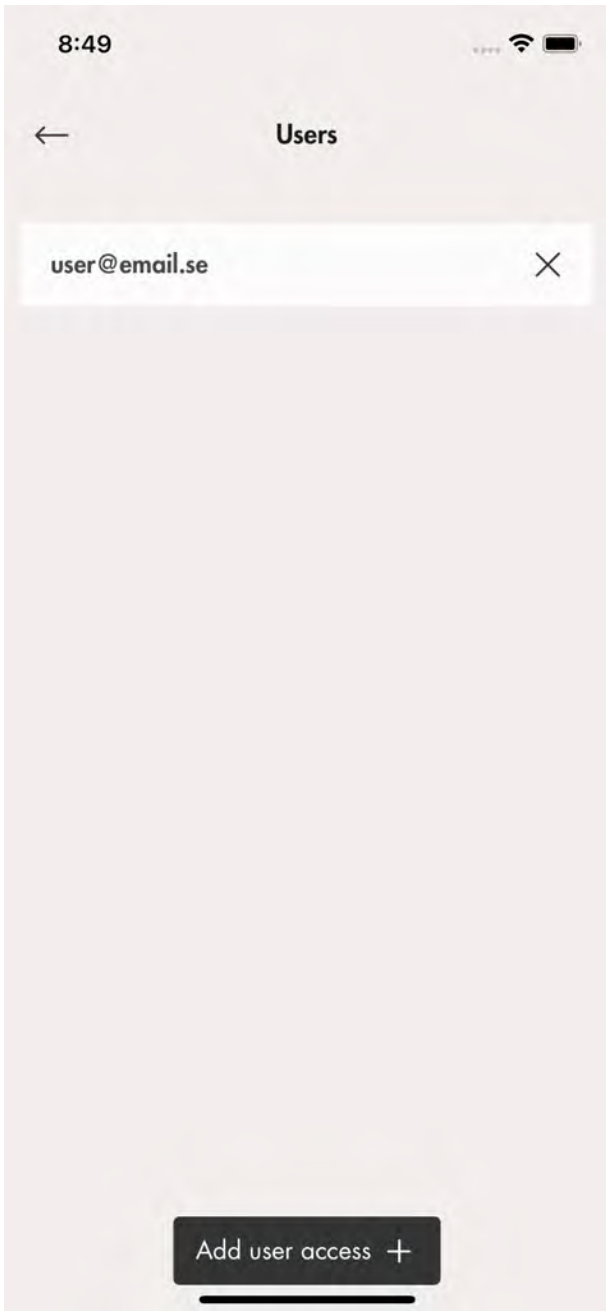

- Create a charger group for the charging stations

A charger group is used to manage access control of several charging stations, for example "Northern parking". Access control can be done both on individual level and on group level. It is not mandatory to create charger groups during the installation process. It is possible to create charger groups at a later time.

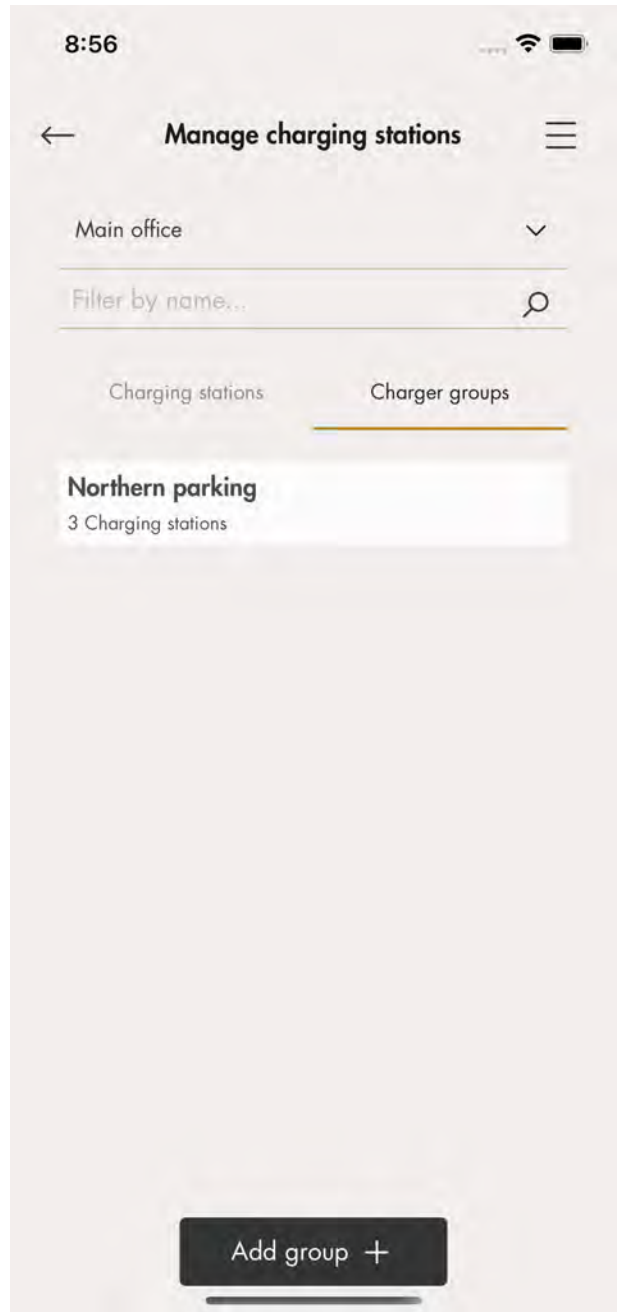

- Cluster EV drivers
EV drivers can be managed in clusters called EV driver groups, which makes access management easier. EV driver groups are related to the

organization, which means they can be used in several locations within an organization.

The organization is a good tool when administrating several locations.

The owner is normally given default access to use the charging stations of the location.

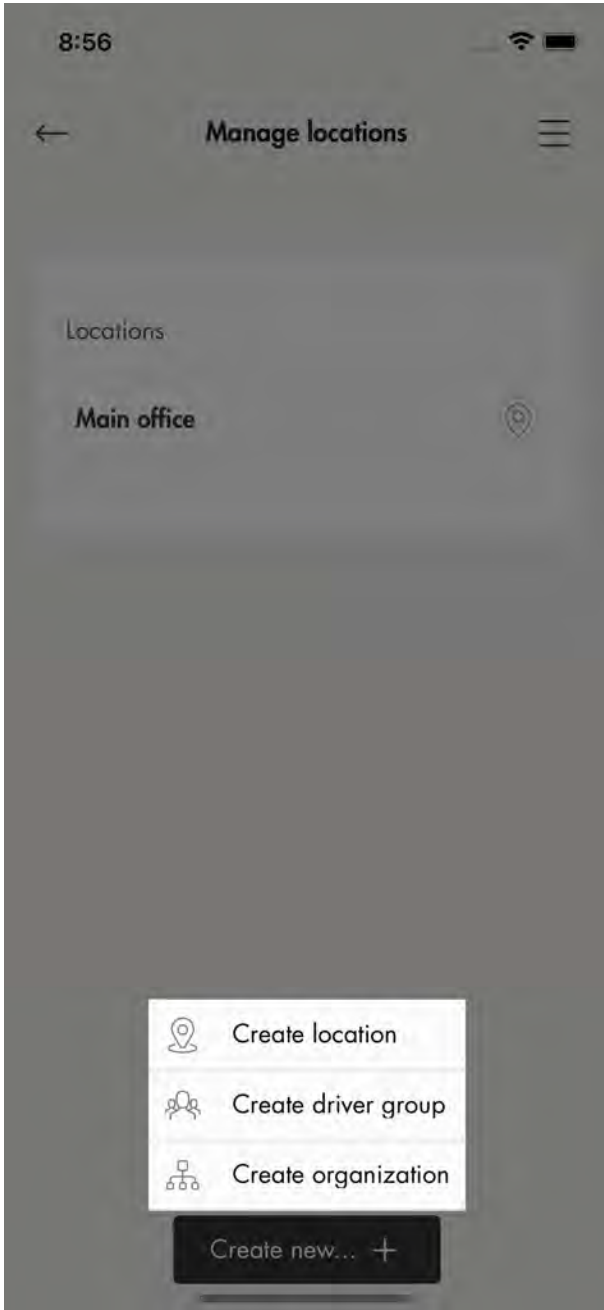

- Advanced owner tools

Additional owners can be added and removed to a location and organization. However, an organization and location must always have at least 1 owner.

A location can also be handed over to another owner (example "sold to").

4.14.5 INSTALLER

The installer is a certified installer or acts on behalf of a certified installer. The installer is hired by the owner to perform the electrical steps of the installation of the charging station(s) that is connected to a location.

To access a location for installation, the owner of the location creates/generates an installation code. The installation code is a 12 letter code that works like a key to the location. The code can be handed over to an installer by email, paper or any other media. Installer must have the code to start an installation.

If a new installation code is generated by the owner, the old one is invalid, like a key.

The installation process of the installer is described in the illustration below. For a full instruction, refer to [To prepare the installation \(installer\), page 68](#).

NOTE

When a new installation is started, the installer can act as a temporary owner and then hand over ownership of the product(s) to the owner.



1. Enter the installation code in the GARO Connect app. The installation code is related to a location.
2. Select the location that the owner has set up.
3. Create or choose charging station.
4. Perform the physical installation. Refer to [4 Installation, page 19](#).
5. Connect the selected, logical charging station to a physical installation bracket, by scanning the IB QR code.
6. Set up the internet connection for the charging station(s).

7. Perform necessary firmware update.

NOTE

Updating using modem as internet access takes long time.

8. Perform the configuration settings.
9. Create connection groups and install load interfaces (if needed).
10. Perform test charging to make sure that the charging station(s) operate correctly.
11. Declare the installation as complete in the GARO Connect app and hand over the installation to the owner. If the installer created the location, it should be transferred to the real owner.

To prepare the installation (installer)

NOTE

These instructions are for the installer. To see the whole process overview of the GARO Connect app, refer to [4.14.2 GARO Connect app process overview, page 57](#). To see the overview of the symbols and buttons in the GARO Connect app, refer to [4.14.3 GARO Connect app symbols overview, page 58](#).

1. Download the GARO Connect app.

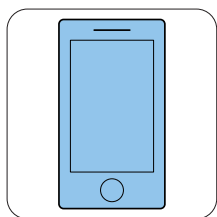

2. Log on to the GARO Connect app with provided credentials. If it is the first time logging in, edit personal settings.

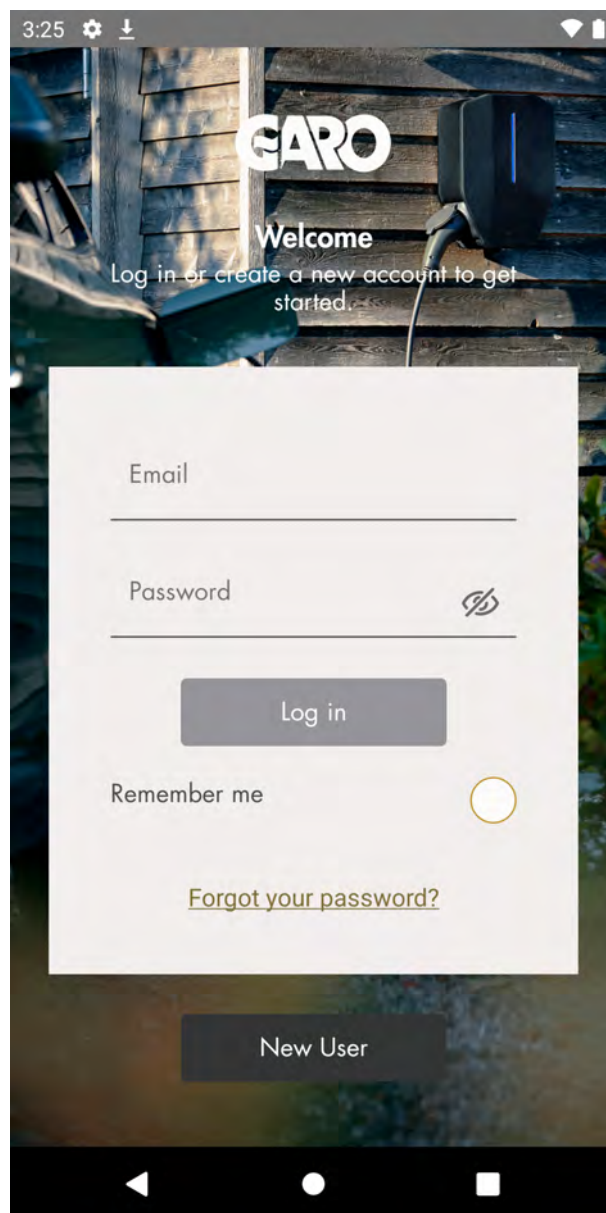

3. Choose *Installers menu*.

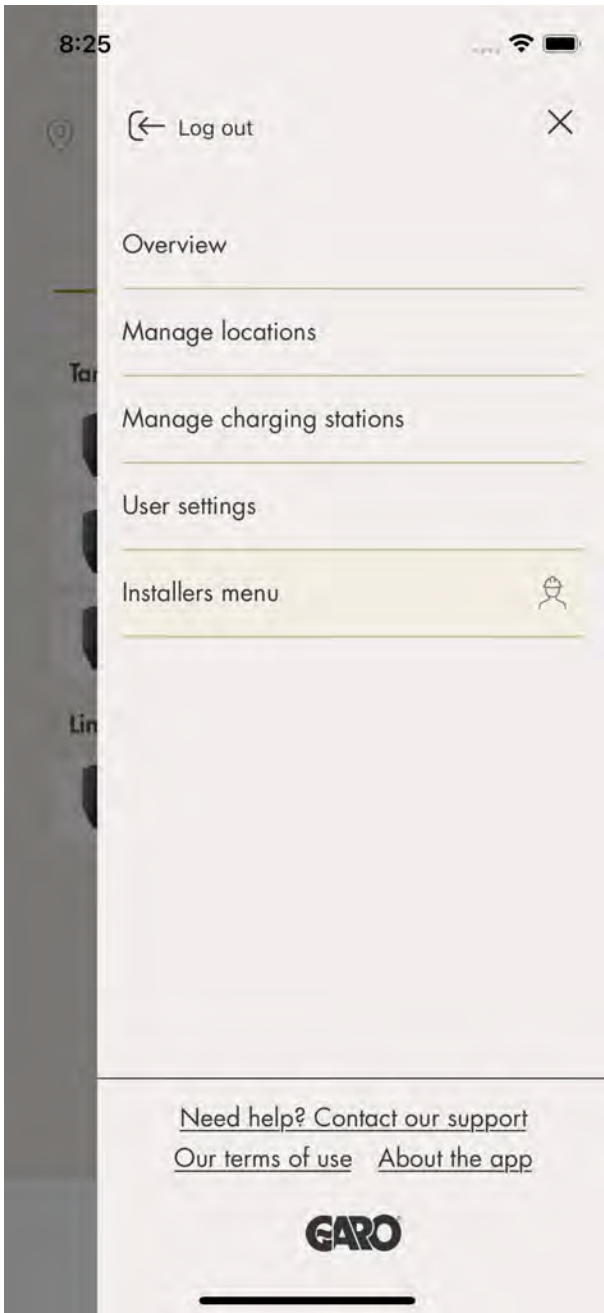

4. Select either *New installation for new location* or *Change installation for existing location*.



5. *Change installation for existing location*: Select a location.

6. Enter the installation code provided by the owner.

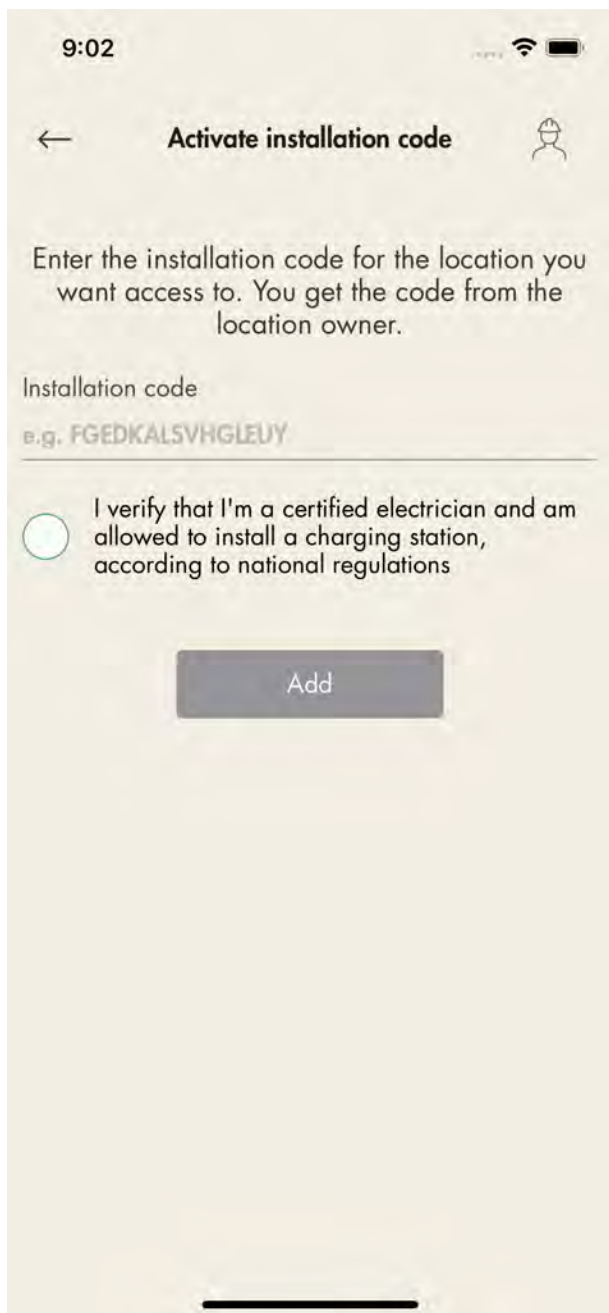

NOTE

To access a location for installation, the owner of the location creates/generates a 12 letter installation code that works like a key to the location. The code can be handed over to an installer by email, paper or any other media. The installer must have the code to start an installation. If a new installation code is generated by the owner, the old code becomes invalid and cannot be used. A location is normally equal to an electrical mains system of a building/site/area. The installation code is only required one time per location.

7. *New installation for new location:* Create a new installation for a new location. During the installation, which starts with the creation of the location, the installer acts as a temporary owner. After the installation, the location is transferred to the actual owner.

To install a unit (installer)

1. Select the location to install the unit(s) in.

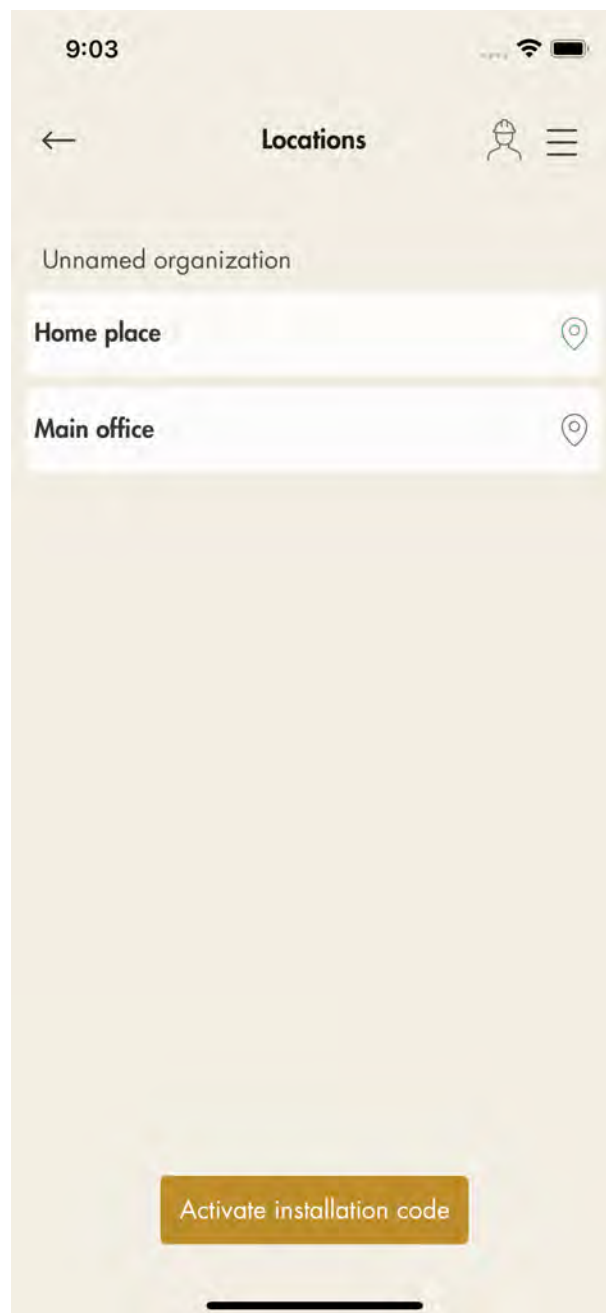

2. Click *Add new unit*.

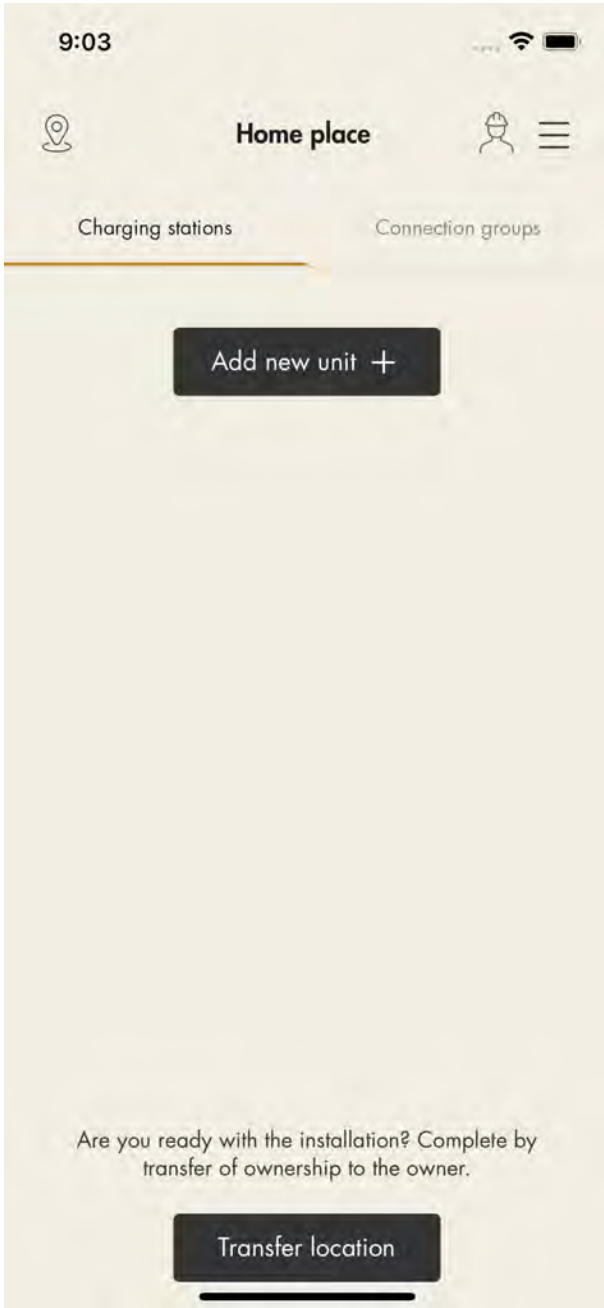

3. Enter a device name and select *Garro Entity* for charging stations or *Garro Entity Balance* for load interface units. The Garro Connect app provides the applicable installation guide based on this choice, even though the installation for each unit type is almost the same.

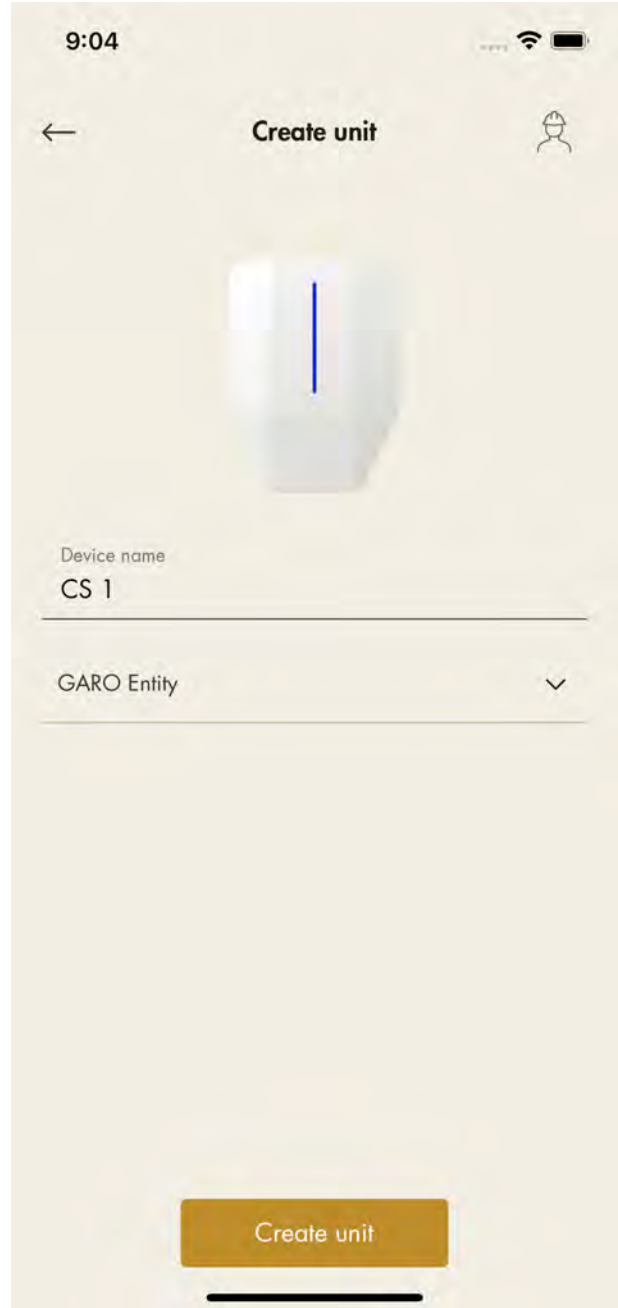

4. Once the unit is added, connect the unit to a group. Click the unit to connect it to a group.

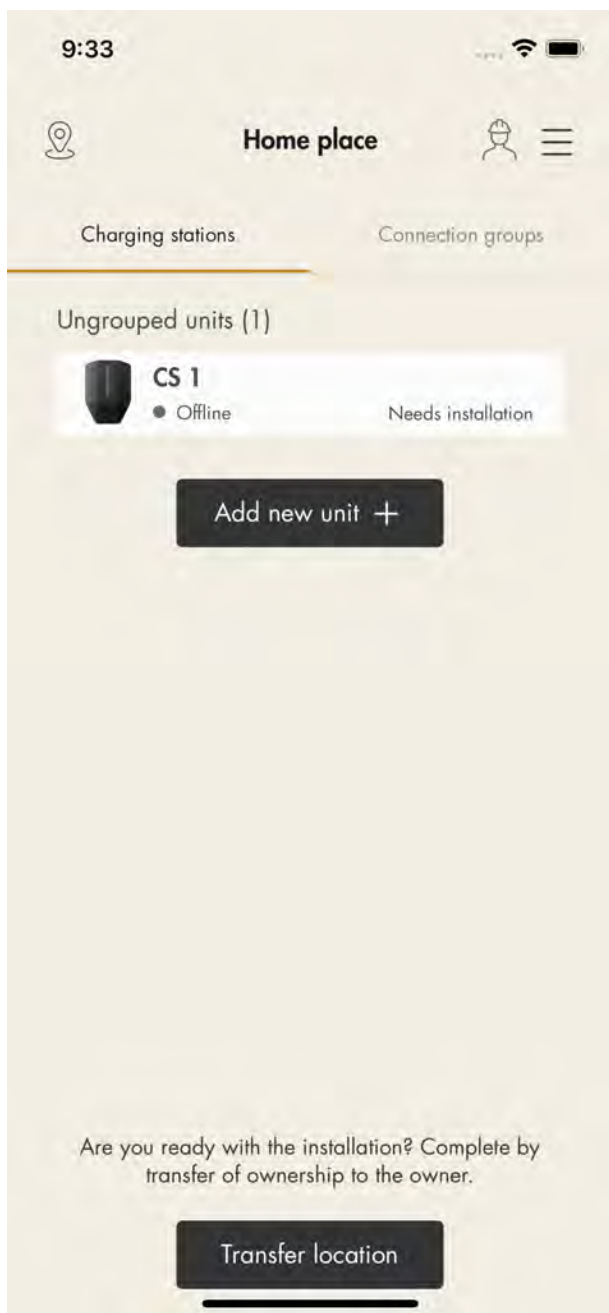

NOTE

In this example, CS 1 will act as an internet gateway, therefore the group structure is set up with this unit first.



NOTE

All units, even a single charging station, must be tied to a group. The workflow of adding units must follow the connectivity and the DLM structural paths. Always start with the unit that will act as the internet gateway followed by the closest units of the different levels. If more units are installed and shall work together in a DLM system, all must belong to the same communication group structure.

	<p><i>Crown icon</i> = DLM master (Manage group load balancing)</p>
	<p><i>Internet icon</i> = Internet gateway/group (Internet master, communication master (manage communication groups), acting master to a mesh Wi-Fi network, "first node" in a "Wi-Fi-mesh").</p>

NOTE

To make a DLM work, all units in the DLM must be part of a structured communication group. In small installations, only 1 internet gateway/communication master is required.

5. Enter a group name and set the maximum current (Ampere) for the group.

This is also required for a single charging station installation. If a charging station is only installed to act as an internet gateway, that is create internet access and net access, then this group size can be set to the maximum current of the charging station. In such an instance, the group is never used for any direct DLM function.

If the first created group is to be used as an active DLM group, then it is recommended that the actual DLM current limit is entered.

9:06

← CS 1

Each unit that is installed belongs to a group. This applies to the installation of individual units.

Group name
DLM home

Group/Charging station max current (A)
25

(0 - 5000 A)

Next

6. An installation guide opens and shows the required steps to install the unit. *All steps must be completed to finalize the installation.*
7. Configuration.
 - a. Install the charging station(s). Refer to [4 Installation, page 19](#).
 - b. Scan the QR code on the bracket.

If the QR cannot be scanned, manually enter the ID.

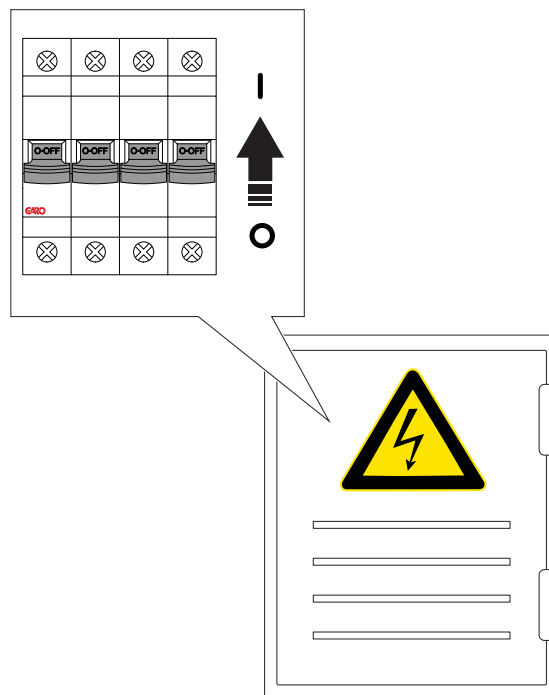

8. Internet setup.

- a. To set the internet connection settings for the first unit, the internet gateway, a direct connection must be set up between the device (mobile with the GARO Connect app) and the charging station.

c. Attach the charging unit and turn the power/voltage on.



To set up a direct connection, use the charging unit ID label to enter the credentials to the GARO Connect app. The QR code is scanned via the GARO Connect app.

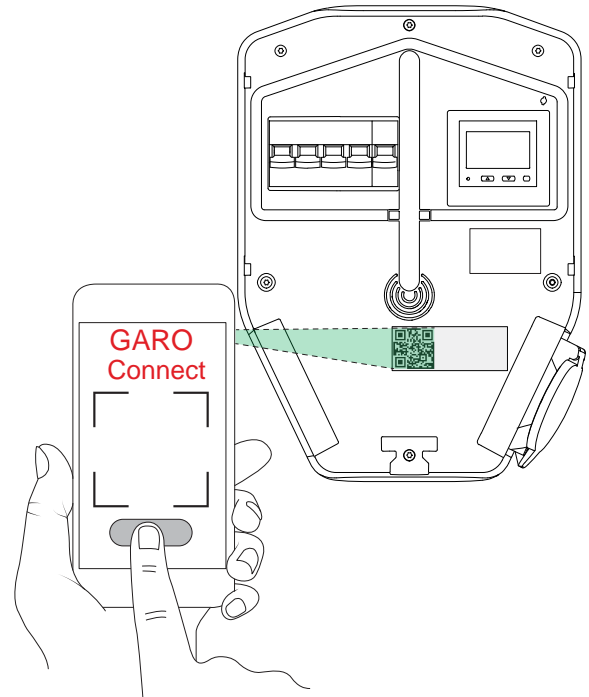

NOTE

It is also possible to enter the Wi-Fi credentials as plain text in the GARO Connect app, if the QR code can not be used.

- b. Wait until the box lights up with a solid green light. This can take up to 5 minutes.



- c. Select how to connect to the internet:
- ethernet cable to router
 - local Wi-Fi connection to existing Wi-Fi with internet router
 - modem
 - as a temporary solution, a hotspot from the mobile device

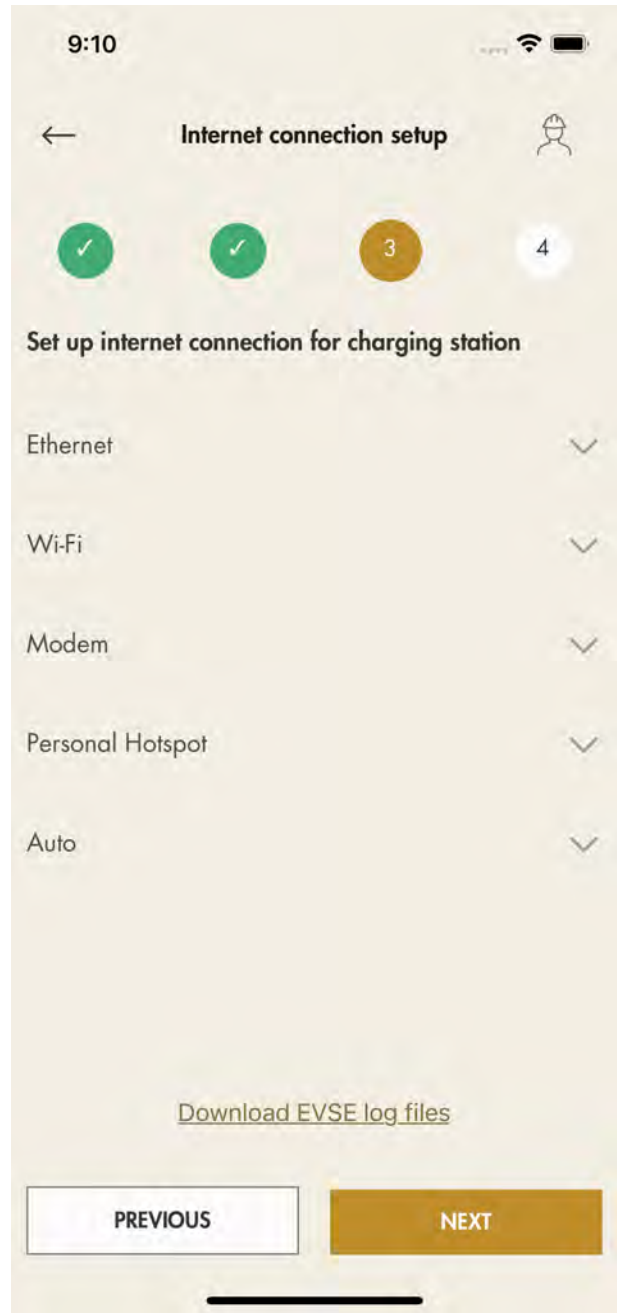

- d. The internet media icon will turn green once connected to the internet.
- e. Close the connection between the mobile device and the charging station.
- Once the internet is connected to the unit, the mobile device will communicate with the unit over the internet, so the direct connection shall be closed.

NOTE

Changing internet settings will force the charging station to a restart.

9. Software update.

Software can always be updated, but never downgraded as this is not allowed due to cyber security. It is highly recommended to enable automatic update of firmware (default setting).

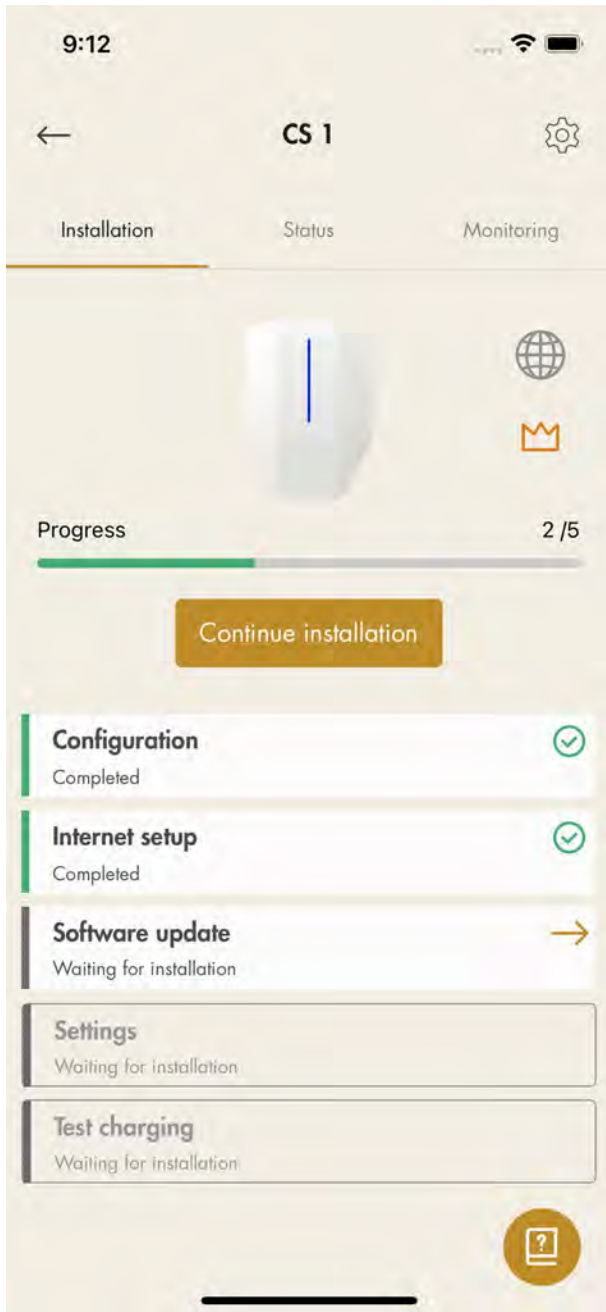

NOTE

A software update over a modem can sometimes be very time consuming. It is possible to update at a later date.

10. Settings.

There are several configuration settings that are possible to adjust with the GARO Connect app. In the GARO Connect app, information is available as support for each available setting. If it is necessary, speak to the GARO support organization for further assistance. Some settings require a restart to take effect.

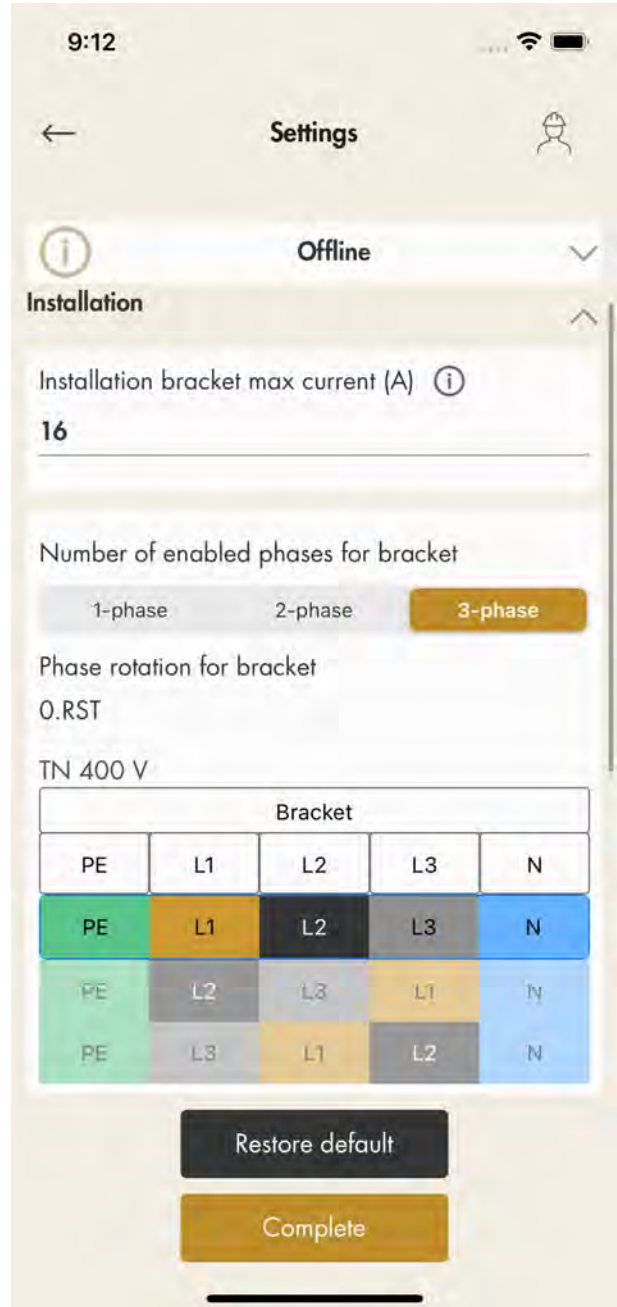

NOTE

For information on the different parameters, click the “i” icon.

11. Test charging and the ground fault protection, refer to [6.4 To do an earth fault test, page 89](#). Test the

charging station using an EV tester or an EV, refer to [4.12.15 To do a final functionality test of the product, page 41](#). Finalize the installation.

12. Declare installation as completed.

After final testing, the installation of the charging unit can be declared ready in the GARO Connect app by clicking *Completed*. The charging unit becomes available to use and visible to the owner.

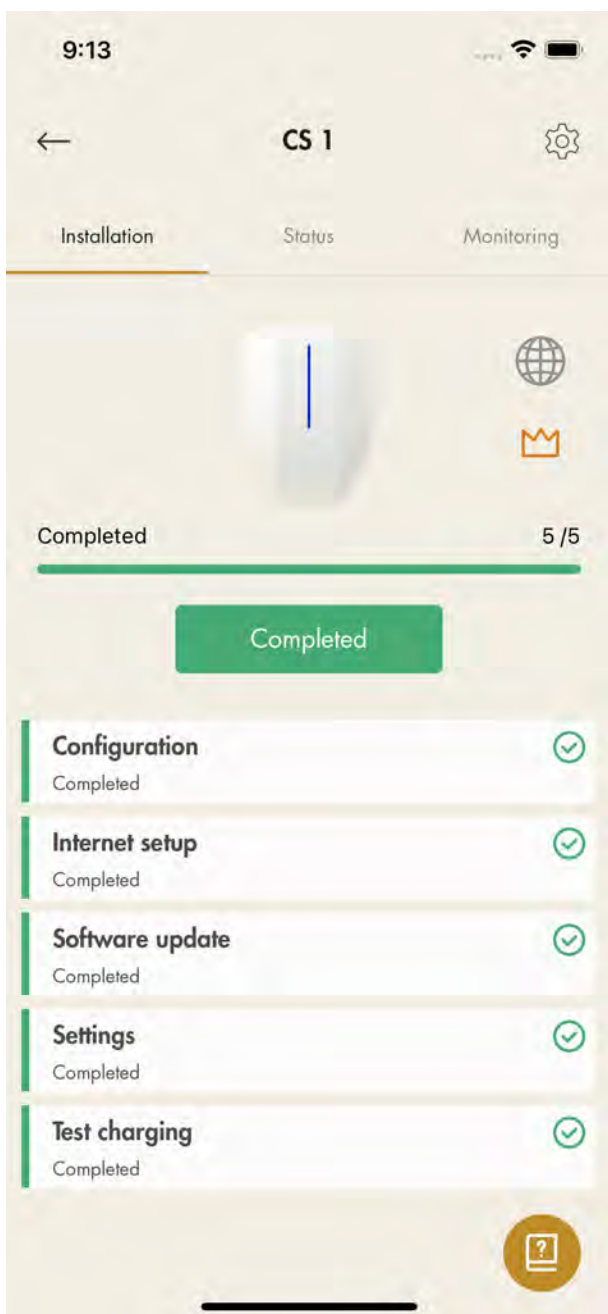

NOTE

After the installation is complete each charging station can be activated and deactivated. A deactivated charging station is indicated as red.

13. Remove the ID label from the charging unit.



14. Functional test

The Wi-Fi credentials on this label can be used to gain unauthorized access to the charging station. For this reason, the information should be considered as sensitive. Place it on a safe space location, for example on the rear side of the charging unit.

Perform the necessary functionality tests such as testing the load management setup to ensure the current is limited at high load conditions, refer to [4.12.15 To do a final functionality test of the product, page 41](#).

To install additional charging stations and load interfaces into a DLM group

If additional units are installed into a DLM system, each unit must be defined into a group structure. The GARO Connect app tool controls the workflow order, adding one unit at a time following the closest relationships.

The example below show how to add the ungrouped load interface main fuse unit into the DLM home group structure. The DLM home group unit has already been created for unit CS 1.

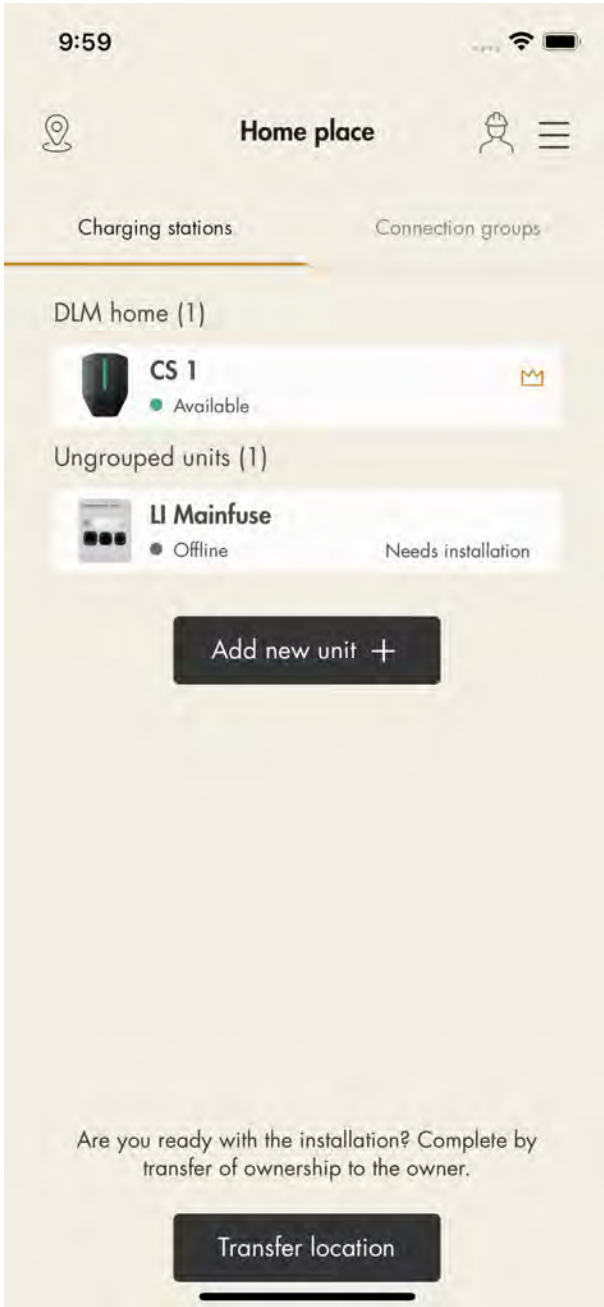

1. To connect a unit to a group, click the unit to connect and select a suitable group structure.
 - a. Add the unit to an existing group.
 - b. Create a new superior group.
 - c. Create a new subgroup.
 - d. Create a new stand-alone group.

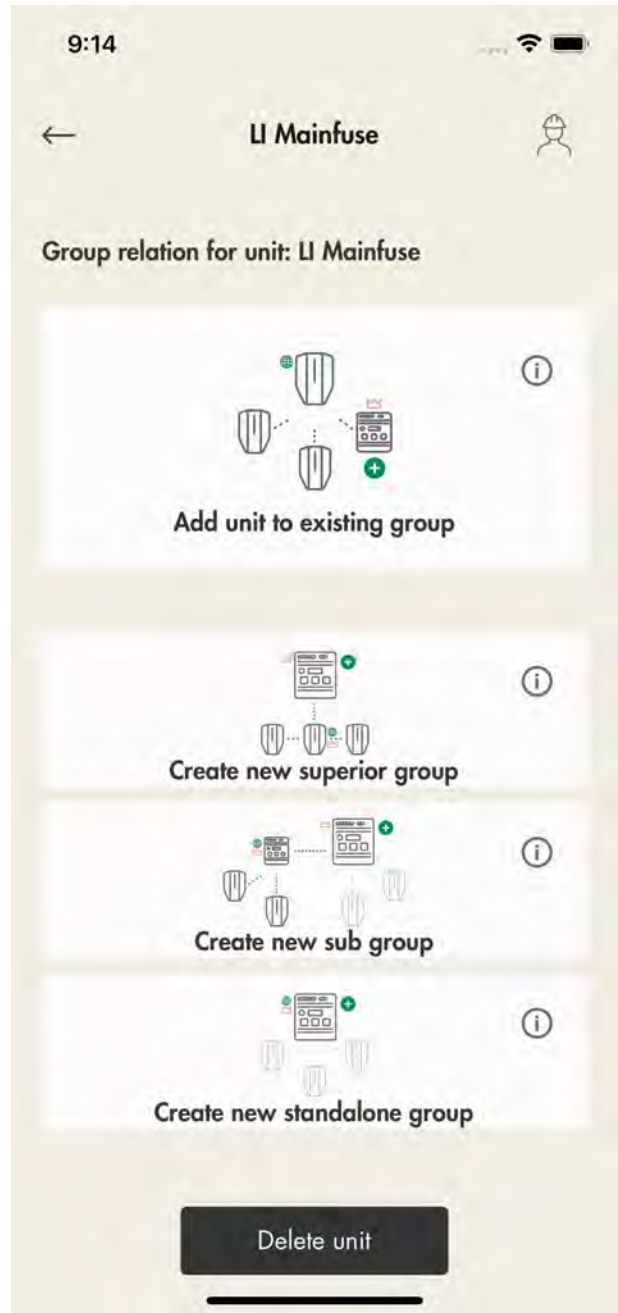

2. To add a unit to an existing group, select a group and click Next.

NOTE

To add a unit to an existing group as a subgroup, name the unit, group current (maximum current) and define the superior group.

When a new subgroup is defined, the default proposal is to also define a new subcommunication master. This is usually a good thing to do in order to avoid reaching the limit of 32 units in a communication group. Another reason to create a

subgroup is that if a Wi-Fi meshgroup is to be "started".

3. Choose connection type.

The connection type defines how the interconnection to the communication master is done. By selecting ethernet cable or Wi-Fi mesh, the connection should be quite automated, without additional need of connection configurations later during the installation process. Use the same method as when adding the first internet gateway.

NOTE

If the interconnection uses Wi-Fi to an external IT-infrastructure, then the Wi-Fi credentials must be defined later in the installation flow, using the direct connection AP to the charging station.

4. In the preview of the connection group icons indicate that unit is set as DLM and connection group masters.

NOTE

The group is not fully created until the ID is set.

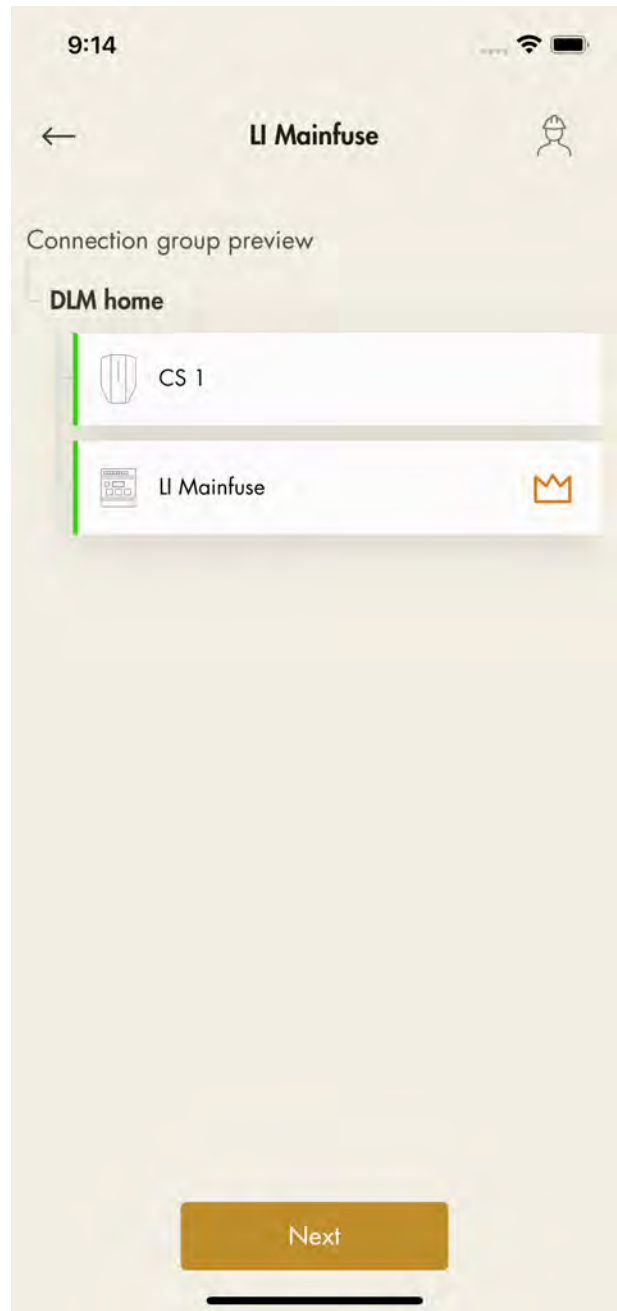

5. Click *Next* to continue the installation. Complete the remaining installation steps and declare the installation finished in the GARO Connect app.

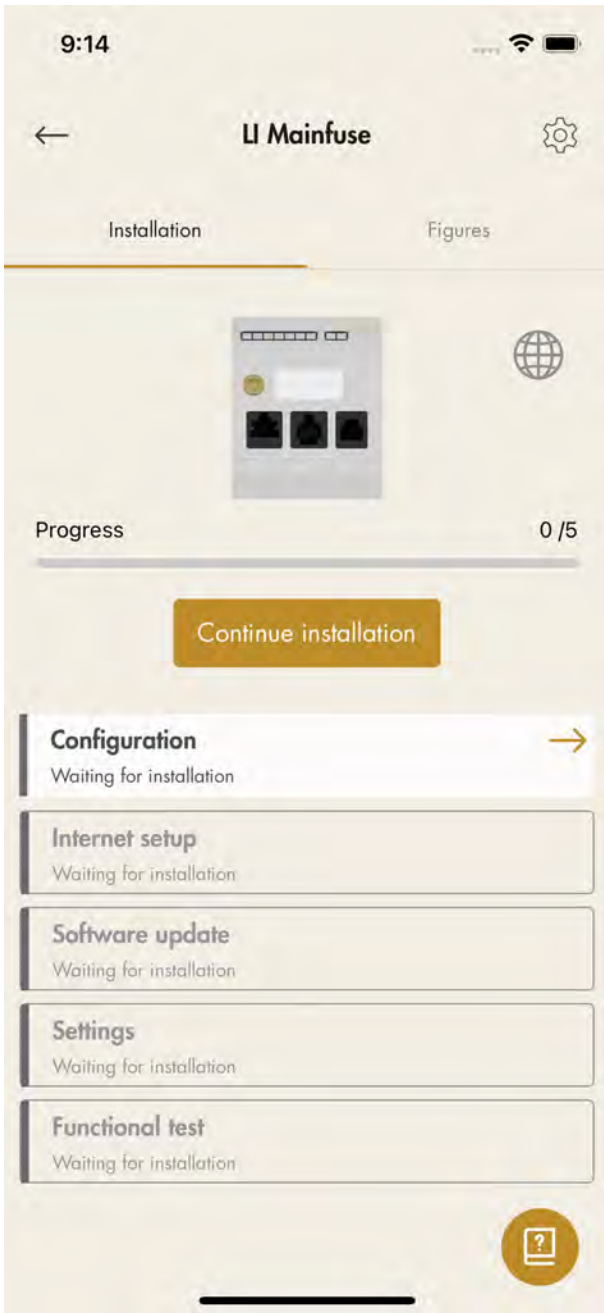

6. The unit is added to the selected group.

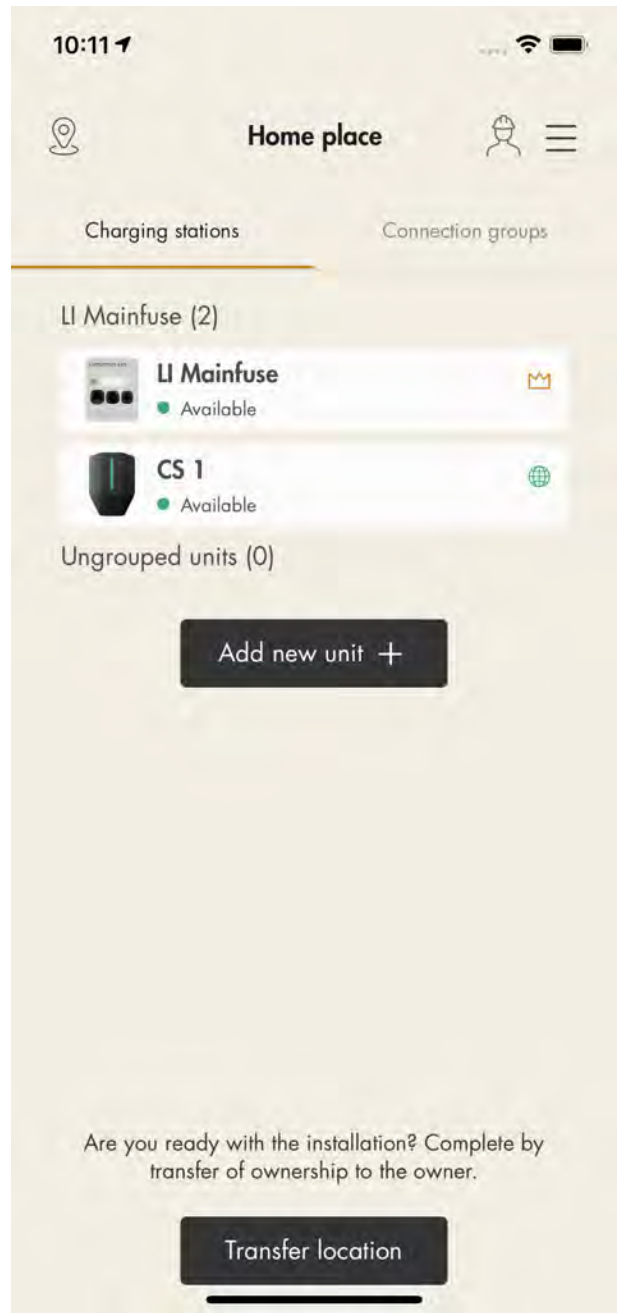

7. View the hierarchy of the DLM groups and Internet groups under *Connection groups*.

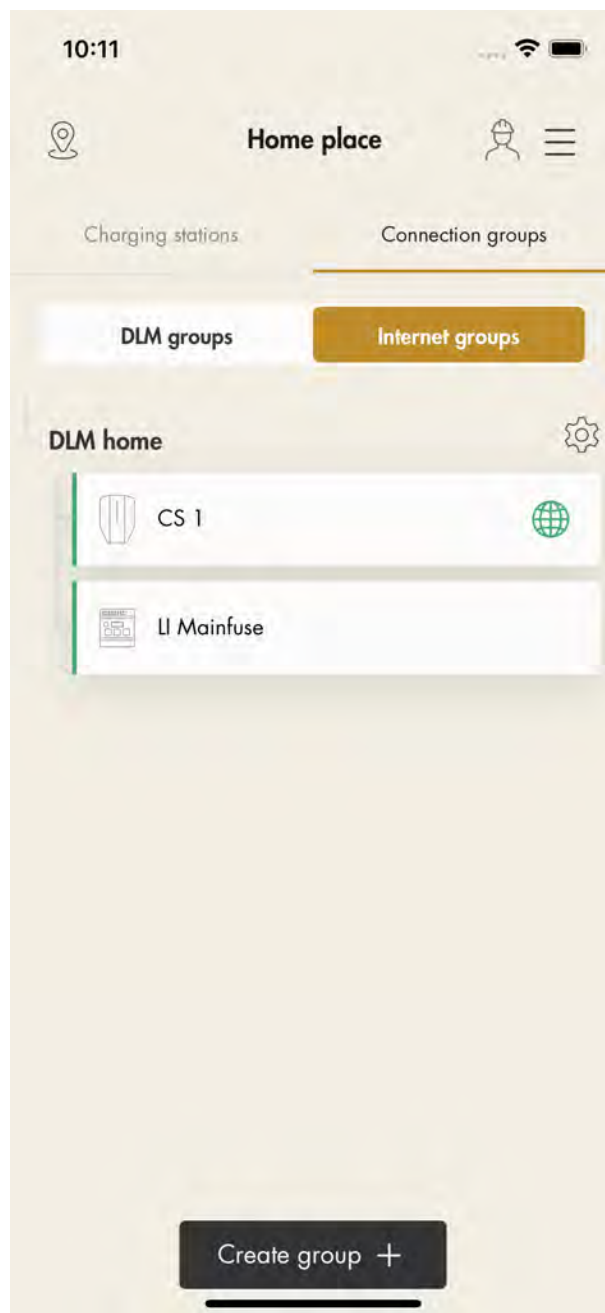
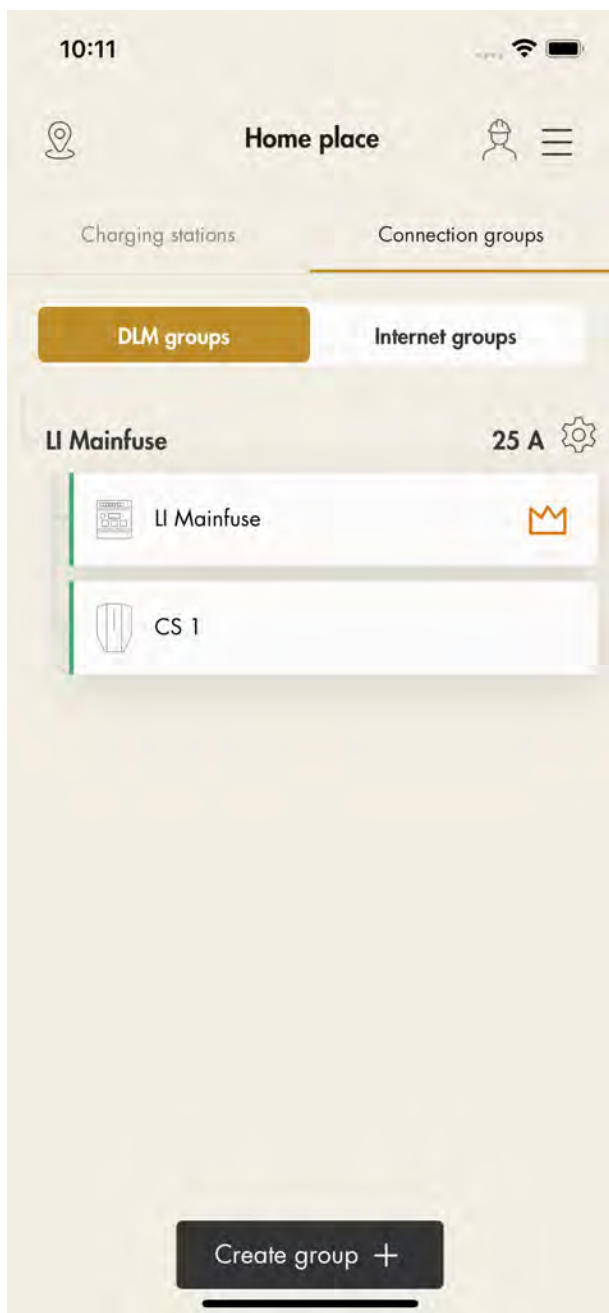

- Continue to install the remaining settings.

However, the internet connection should be automatic if an ethernet cable or a mesh Wi-Fi is used. If a Wi-Fi connection is used, follow the instructions in the GARO Connect app.

Transfer location

If the installation is performed on behalf of the owner, transfer the location back to the owner.

To do this, click *Transfer location* and follow the instructions in the GARO Connect app.

NOTE

If the owner is not a user of the GARO Connect app, an invitation will be sent out via email.

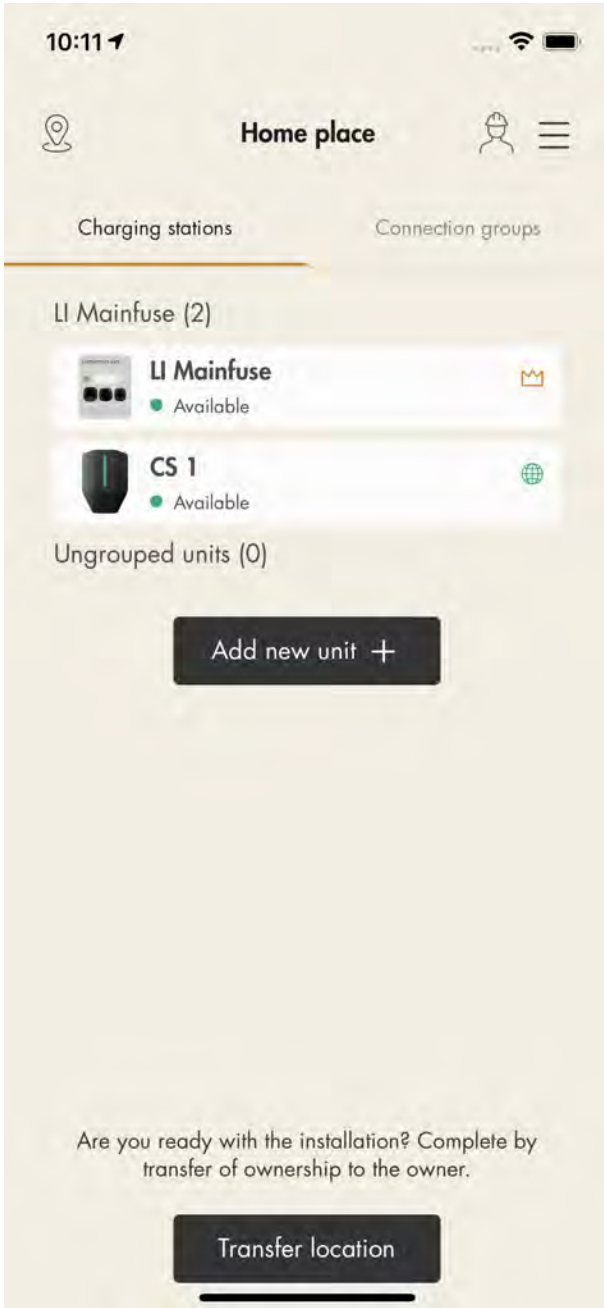

5 OPERATION

WARNING

Read and understand the safety chapter before operation of the product. Refer to [2.1 Safety definitions, page 9](#).

5.1 TO CHARGE AN ELECTRICAL VEHICLE

1. If the charging station has a Type 2 outlet, connect a charging cable to the Type 2 outlet.

NOTE

It is possible to lock the charging cable to a Type 2 outlet using the Garo Connect app. It is only the EV driver that has locked the charging cable and the owner of the charging station that can unlock the charging cable. If an EV driver uses free use without using the GARO Connect app or RFID (not necessary), this energy will not be logged to the EV driver's registered consumption. But if the EV driver identifies themselves on a free use charging station before attaching the EV, then the charged energy is registered to the EV driver.

2. Connect the charging cable to the EV.
3. If the charging station gives a yellow blinking light indication, authorization is necessary. Do one of the steps that follow:

NOTE

If the charging station is set to free use mode (default), no authorization will be necessary and the charging starts immediately. This also means that the consumption of energy is not logged or registered to any specific user. To track consumption of an EV when using a charging station in freecharge mode, the EV must be identified before the vehicle is plugged in.

A free use RFID tag ID can be selected, so the consumption is logged on the account of one user.

- a. Either hold your RFID tag against the RFID reader on the charging station.

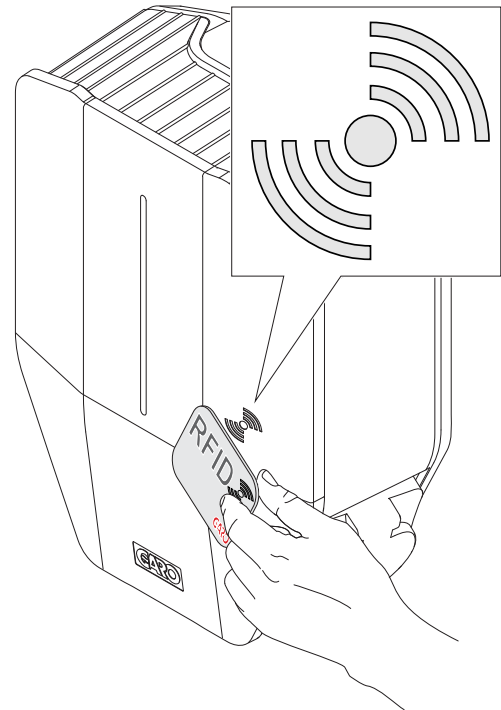

- b. Or log on to the GARO Connect app and choose *Charge and use* (A). Choose location (B) and charging station (C).

The charging starts after authorization.

NOTE

The following settings are also available in the GARO Connect app.

- Schedule the charging.
- Manage personal settings and the personal RFID tags.
- Monitor the charging process.
- Do a check of the status and location of charging stations that are accessible to the user.

Also, ongoing sessions can be monitored and the charging history analyzed.

5.1.1 INDICATION LIGHT

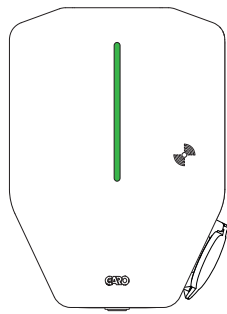

A			H		
B			I		
C			J		
D			K		
E			L		
F			M		
G					

	When	Meaning
A	Green solid light.	The charging station is available for charging.
B	Green slow blinking light, 1 Hz.	The charging station waits for either a connection to or a disconnection of an EV.
C	Yellow solid light.	The Type 2 contact is not in correct position. Try to reconnect.
D	Yellow slow blinking light, 1 Hz.	The charging station is reserved and/or awaits authorization by the EV Driver.
E	Yellow fast blinking light, 10 Hz.	The authorization of the EV driver is checked.
F	Blue pulsating light, 1 Hz.	The EV charges.
G	Blue slow blinking light.	The charging awaits the time schedule to start the charging process.
H	Blue solid light.	The charging process is finished by the EV.

I	Red solid light.	The charging station is deactivated by the GARO Connect app or the external enable signal. Example: A schedule that does not yet enable charging.
J	Red slow blinking light, 0.5 Hz.	Error in the charging station or the EV. Disconnect the EV and retry. If the breaker has tripped, a manual reset is required.
K	Red fast blinking light for 3 seconds, 10 Hz.	The charging station cannot find authorization for the EV driver.
L	Red and blue slow blinking light, 1 Hz.	Software update in progress.
M	No light.	The charging station has no power or the intensity of the indication light is reduced.

5.2 TO SCHEDULE CHARGING

1. Open the GARO Connect app on a mobile device.
2. Navigate to *Overview*.
3. In the view *Charging stations* click the charging station to set a schedule.
4. Scheduled charging is indicated by: Red light when not activated, green light when activated and blue when both activated and an EV is connected.
5. Click *Schedule Charging* in the view that opens.
6. Follow the instructions in the GARO Connect app to set the time for charging.

5.3 TO STOP THE CHARGING OF THE ELECTRICAL VEHICLE

1. Do one of the procedures that follow to stop the charging.
 - a. Follow the instructions for the electrical vehicle, i.e. the EV will initiate a charging stop.
 - b. Use a RFID that is connected to same EV driver that started the charging. Only the EV driver that started the charging can stop it.

- c. Use the GARO Connect app and log in as the EV driver that started the charging.
2. Disconnect the Type 2 connector from the electrical vehicle.

CAUTION

The Type 2 connector is locked during charging in the charging station and the electrical vehicle inlet. Do not force the Type 2 connector or charging cable as this can cause damage to the product or the electrical vehicle.

3. If there is a Type 2 outlet in the charging station, disconnect the Type 2 connector from the Type 2 outlet in the charging station.
4. If there is a fixed cable on the charging station, put the Type 2 connector in the dedicated parking position on the charging station.

CAUTION

Do not leave the Type 2 contact on the ground. Always hang it up or store it in a dry location.

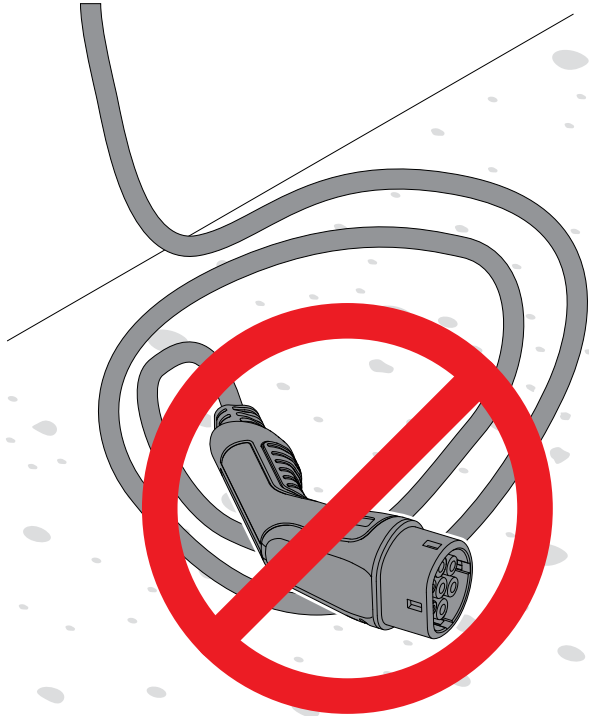

6 MAINTENANCE

6.1 TO CLEAN THE CHARGING STATION

- Use a damp cloth to clean the exterior of the charging station.

CAUTION

Do not use running water or a hard brush to clean the charging station, it can cause damage.

6.2 TO DO A VISUAL CHECK OF THE CHARGING STATION

1. Make sure that the charging station is clean.
2. Do a visual check of the charging station, Type 2 connector and the power cables. Do a check for damages such as cracks or deformation.

WARNING

Do not use a damaged charging station. Turn off the electric power and disable the charging station in the GARO Connect app. Contact an authorized service center.

6.3 TO DO A FACTORY RESET

CAUTION

The GARO support organization should approve a factory reset. The factory reset should only be done as a last resort in case of errors, such as lost contact to the network or the GARO Connect app.

1. Stop charging and disconnect any EV.
2. Remove the front cover of the charging unit, refer to [4.12.16 To mount the front cover of the charging unit, page 43](#).
3. Do a long press, approximately 20 seconds, on the test button (T) with the designation "T". Use a pen or similar. When pressing the button, the circuit breaker will trip. The indication turns into a blinking red light.

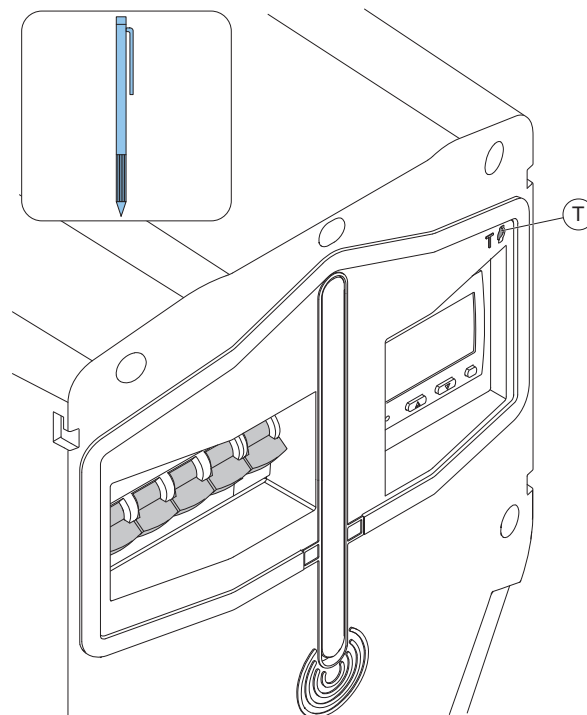

4. After the light goes off, release the button and the circuit breaker can be closed.
5. Wait for the device to restart and the light to turn green.

6.4 TO DO AN EARTH FAULT TEST

NOTE

Do an earth fault test 2 times/year.

1. Remove the front cover of the charging station, refer to [4.12.16 To mount the front cover of the charging unit, page 43](#).
2. Do a short press (max. 1 second) on the test button (T) with the designation "T". Use a pen or similar.

NOTE

When the test button is pressed, the indication light becomes blinking red and the circuit breaker trips.

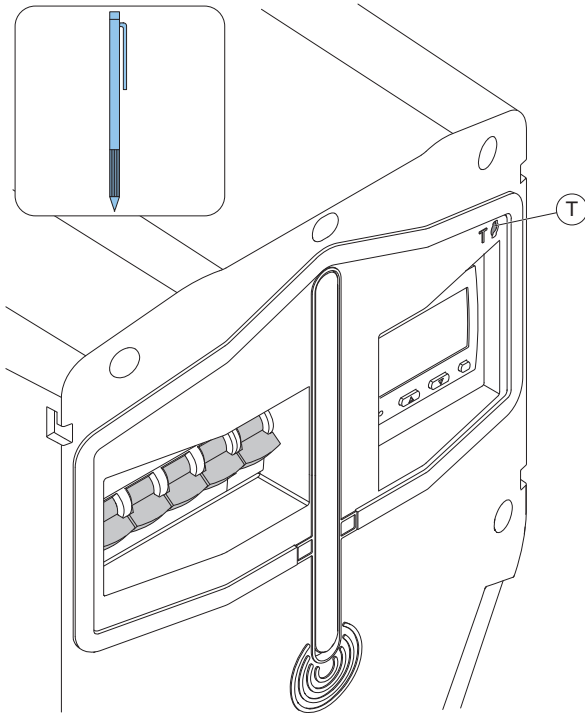

3. Unplug the electric vehicle (EV).
4. If the charging station still indicates red, the circuit breaker needs to be reset. Open the front cover of the charging station.
5. Lift the switch arm up to reset the circuit breaker.

NOTE

The circuit breaker can have 4 or 2 poles (three- or one-phase versions).

6.5 TO DO A RESET AFTER A MINOR GROUND FAULT

The charging station can be configured to enable early detection of a ground fault or overload by an EV. This is a setting made by the installer. This is indicated by a slow blinking (0.5 Hz) red indication light.

As charging is stopped, disconnect the EV. The charging station will reset after a few seconds. A green light indicates if all is OK.

If no green light lights up, contact the owner of the charging station to perform a reset of the circuit breaker.

6.6 TO DO A RESET OF A TRIPPED CIRCUIT BREAKER

If the circuit breaker trips, the light status indication on the charging unit becomes a slow blinking (0.5 Hz) red. If it is configured, a notification is sent to the owner and the EV driver that uses the charging station, in the GARO Connect app. The circuit breaker can trip either due to an earth fault, short circuit or overload.

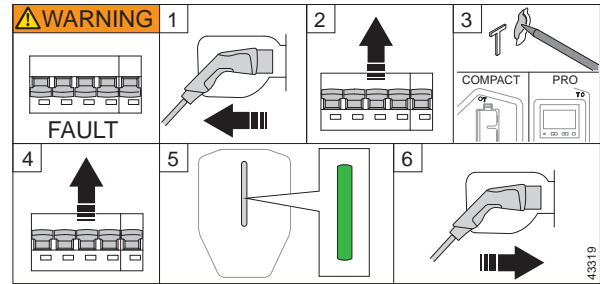

1. If there is an EV or cable connected to the charging station, unplug the Type 2 charging connector. Unlock and remove the front cover of the charging unit, refer to [4.12.16 To mount the front cover of the charging unit, page 43](#). Do a visual check of all cables and connectors.
2. Lift the switch arm up to reset the circuit breaker.
3. Do an earth fault test, refer to [6.4 To do an earth fault test, page 89](#). This should trip the circuit breaker.
4. Reset the circuit breaker.
5. Wait for the indication light to turn green. Put the front cover back on. If the circuit breaker trips immediately, do not use the charging station. Contact an installer or a service center.
6. Connect and charge the electrical vehicle again.

CAUTION

Do not perform repeated tests on a faulty EV or charging station. This may result in damages to the EV or charging station.

If the circuit breaker does not trip again, reinstall the front cover of the charging unit.

6.7 TO REPLACE A CHARGING UNIT

WARNING

Necessary knowledge to replace a charging unit is required. If unsure, speak to an installer.

If the charging unit is damaged, it is necessary to replace it. To replace a single charging station, or a master charging station, or a charging station connected to a local Wi-Fi, a smartphone and the Garo Connect app are required. Refer to [4.14 GARO Connect](#), page 56.

1. Turn the power/voltage off.

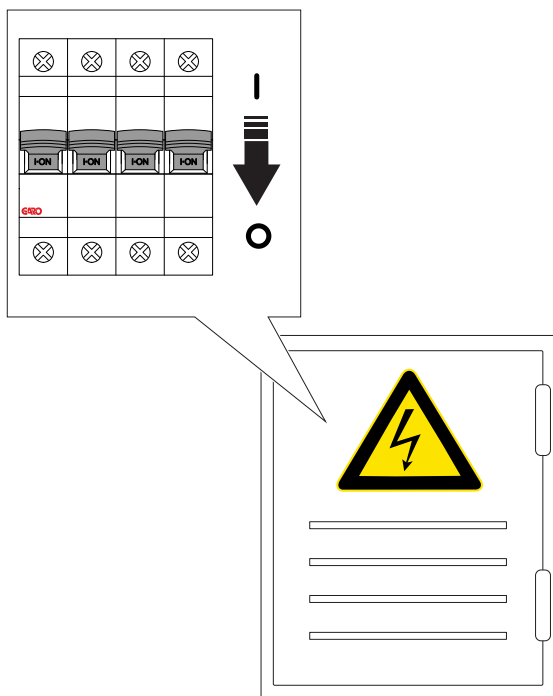

2. Unlock and remove the front cover of the charging unit, refer to [4.12.16 To mount the front cover of the charging unit](#), page 43.
3. Remove the 6 screws (TX20) that hold the charging unit to the installation bracket, and pull the charging unit out of the installation bracket.
4. Never leave an installation bracket empty. If the installation bracket is not used, it should be protected by a cover. The cover is available as a separate part.
5. Disconnect the ethernet cable(s) and control cable, if used, from the charging unit.

6. Examine the installation bracket for damages.
 - a. If the installation bracket is damaged, an installer must remove it from the wall or pole and install a new installation bracket. This requires that the charging station must be installed again, connecting it to the new identity of the installation bracket.

WARNING

Only an authorized installer, or a person acting on behalf of an authorized installer, may replace the installation bracket.

NOTE

Only 1 installation bracket can be installed, connected to 1 charging station in the GARO Connect app. If an installation bracket is to be reused in another location, it must first be deleted from the first location.

7. Unpack and inspect the new charging unit.
8. Connect the ethernet cable(s) if used, and the control cable to the new charging unit. Refer to [4.12.10 To install the control cable to the installation bracket](#), page 35.
9. Attach the new charging unit to the installation bracket. Refer to [4.12.14 To attach the charging unit to the installation bracket](#), page 39.
10. If the charging station uses a local Wi-Fi for internet access, do the internet adjustments through the GARO Connect app. This also applies to single/standalone charging stations. Refer to [4.9 To decide internet connection type](#), page 23.
11. Attach and lock the front cover of the charging unit.
12. Turn the power/voltage on.

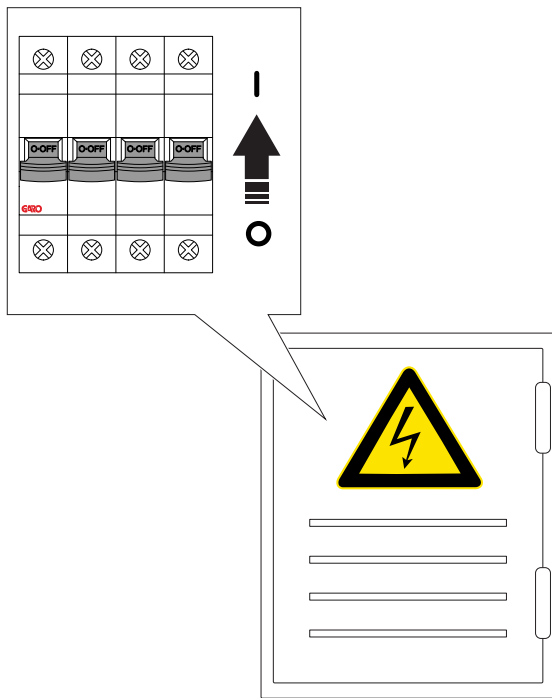

13. Allow the charging unit to download software settings.
14. Do a functional test of the charging unit. Refer to [4.12.15 To do a final functionality test of the product, page 41](#).

6.8 PME - PROTECTIVE MULTIPLE EATHING (UK VERSIONS ONLY)

Some variants of charging units are equipped with Protective Multiple Earthing (PME) protection. By monitoring the phase voltage, a fault in the grid-connected earth connection (PEN conductor) can be detected. Detection level is phase voltage $<207\text{ V OR }>253\text{ V}$. In case of detected fault, any charging is stopped, the EV is isolated (Live, Neutral and PE). The charging station indicates blinking red.

Action when triggered:

(A red, slow blinking (0.5 Hz) indication on the charging station LED, an error message can be read in the GARO Connect app). A notification is sent to the user and the owner if configured.

1. Disconnect the EV.
2. Contact the installer to investigate the root cause of the problem. Reset the circuit breaker.

3. Press the test button marked "T" to conduct a ground fault test. The circuit breaker should then trip. Refer to [6.4 To do an earth fault test, page 89](#).

If the test is OK and no further uncertainty exists, then the charging station can be used in normal operation. The voltage level can be monitored in the GARO Connect app.

CAUTION

Never use the charging station if any uncertainty exists regarding PEN status or voltage levels.

6.9 SERVICE

The owner of a location is responsible for keeping the installation in a safe condition. One recommended way to fulfil this is to set up a service agreement with a service provider.

CAUTION

Service must only be performed by approved personnel.

Contact GARO to set up a service agreement.

6.10 REPAIR

CAUTION

All repair work must be done by GARO approved service centers.

NOTE

Warranty is void if the sealing label is broken and the charging unit opened.

7 TROUBLESHOOTING

7.1 TROUBLESHOOTING

Problem	Solution
No light on the indication light on the charging station.	<p>Do a check of the power supply to the charging station. Startup takes approximately up to 2 minutes.</p> <p>Do a check of the light intensity setting. If the light intensity is set near 0, it results in no visible light.</p>
The indication light shows a blinking red light (0.5 Hz).	<p>Disconnect the EV.</p> <p>Let the owner do a reset of the circuit breaker. Refer to 6.6 To do a reset of a tripped circuit breaker , page 90.</p> <p>If the above measures to not help, do not use the charging station. Contact the installer or GARO support.</p>
The indication light shows a fixed red light.	<p>The charging station (CS) is deactivated by the owner using the Garo Connect app or a Pro charging station is deactivated by an external enable signal. Example: A charging station is scheduled by by the owner. The charging station indicates a red light when not active, as the charging station is not at that moment available for charging.</p>
The indication light shows a slow blinking yellow light.	<p>Before starting the charging process, do a check of the Type 2 connectors.</p> <p>If the charging process is stopped, remove the charging cable from the Type 2 outlet.</p> <p>Once authentication is received, connect the EV.</p>

<p>The charging power is too low.</p>	<p>Let the owner do a check of the power and current status in the GARO Connect app. The signalled current, that is what the charging station allows the EV to use, can be reduced due to load balance and thermal derating. This information is also available in the GARO Connect app.</p>
<p>There is no charging power but the indication light shows a blue blinking light.</p>	<p>Let the owner do a check of the power and current status in the GARO Connect app. The signalled current, that is what the charging station allows the EV to use, can be reduced due to load balance and thermal derating. This information is also available in the GARO Connect app. No invitation email received from owner or system.</p> <p>Solution: Check if the email is in blocked in the junk email inbox.</p>

8 TECHNICAL DATA

8.1 CHARGING STATION TECHNICAL DATA

Product type	GARO Entity Pro
Standards	IEC 61851-1 IEC 62955 IEC 61439-7 EN 60898-1 EN 61008-1
EMC classification	2014/30/EU
Installation method	Wall in a single and/or double installation bracket. (Stand and pole mount fixtures are available as accessories)
Installation environment	Indoor/outdoor
Location type	Non-restricted access
Rated voltage	TN 2-3 phase 400 VAC 50 Hz TN 1 phase 230 VAC 50 Hz IT/TT 2-3 phase 230 VAC 50 Hz
Rated current	32 A or 20 A depending on fixed cable version. The default setting is always 16 A. The maximum installed current for the charging station (CS) is set by the Installer.
Installation systems	TN, IT and TT systems
Charging type	Type 2/Mode 3
Charging method	AC charging
Protection class	IP54
Mechanical impact resistance	IK10
Temperature range	-40 °C - +40 °C. Charging current is reduced at higher temperatures.

Weight	3-3.7 kg without cable (depending on product variant)
Cable length (fixed cable version)	4.5 m/5 m/8 m NOTE IEC 61851-1 allows max. 7.5 m.
Size single version charging station, height*width*depth	340*240*150 mm
Size double version charging station, height*width*depth	340*495*145 mm
Residual current limit	30mA AC/6mA DC
Rated short-time withstand current	10 kA
Rated conditional short-circuit current of an assembly	10 kA
Short-circuit protective device type	C
Rated impulse withstand voltage	4 kV
Rated insulation voltage	230 V/400 V
Over voltage category	III
Rated diversity factor (RDF)	1
Pollution degree	2
EMC environmental condition	A
RFID Frequency Band	13.56 MHz
RFID output power	300 mW
SIM	3 FF = Micro = 15x25 mm
Modem	Lte Cat M1/Cat Nb2/Egprs
Wi-Fi	802.11 g 2.5 GHz
Maximum pre-fuse to terminal	80 A Char. C
Installation power cable limitations	Maximum area: 16 mm ² , outer diameter: maximum 24 mm

Power connection terminals	2.5–16 mm ² , spring type
Warranty	2 years
Design product life cycle	10 years installation/30 000 hours charging at 20 C
Appliance class. Protection against electric shock	Class I equipment with PE connection

8.2 LOAD INTERFACE TECHNICAL DATA

Standards	EN 62368-1
EMC Classification	2014/30/EU
Installation method	DIN rail.
Installation environment	Indoor/outdoor electrical cabinet.
Location type	Restricted access.
Rated voltage	TN/IT/TT 1-phase 230 VAC 50 Hz
Rated current	13 mA
Installation systems	TN, IT and TT system.
Power	<3W
Protection class	IP20. Appliance class protection against electric shock: Class II.
Connection terminals	1.5 mm ² , spring type.
Temperature range	-20 °C to +50 °C
Weight	0.2 kg
Dimensions (heightxwidthxdepth)	86x72x49 + antenna 110 mm (4 DIN modules).
Color	Grey
Recommended protective pre-fuse	max. C 10 A
Overvoltage category	III (OVC 3)

Rated impulse withstand voltage	4 kV
Rated insulation voltage	230 V
Antenna connection	SMA male.

Type	Load interface, basic	Load interface, advanced
Interface to GARO Entity	1x Ethernet RJ45, Wi-Fi 2.4 GHz, mesh	2x Ethernet RJ45, Wi-Fi 2.4 GHz, mesh
HAN RJ-45 input EN 13757-2	1	N/A
HAN RJ-12 input	1	N/A
Current transformer input 0–333 mV	x3	N/A
Current transformer input 0-5 A	N/A	x3
M-Bus input	N/A	1
Modbus input RS-485	N/A	1
Relay output 12-230 V, 1 A	N/A	1

Implemented energy meters modbus	Implemented enerymeters M-bus
Garro GNM3D-RS485	Garro GNM3D-Mbus
Garro GNM3D-LP RS485	Garro GNM3D-LP Mbus
Garro GMI3D-LP RS485	Carlo Gavazzi EM210 with Rogowski

8.3 ACCESSORIES

For available accessories, refer to the GARO website at www.garo.com.

SOURCE CODE

The software included in this product contains copyrighted software that is licensed under LGPL-2.1, GPL-2.0, and GPL-3.0 and other open source licenses. A copy of the licenses are available in a separate document. Source code can be obtained from GARO for a period of 3 years after the final shipment of the product, which may be no earlier than 2025-01-01 for a fee. For order and payment of the source code document, please contact:

GARO E-Mobility AB

Box 203

335 33 Gnosjö, Sweden

e-mobility@garo.se

EU DECLARATION OF CONFORMITY



Dokument/document		Utgåva datum/edition date
Försäkran om överensstämmelse/ Declaration of conformity		2023-04-13
Avdelning/department		
Produkt/Product		
Ansvarig/prepared	Version	Sida/page
Peter Magnusson	5	1 av/of 1

Manufacturer/Tillverkare: GARO AB
Box 203
S-335 25 GNOSJÖ
Sweden

Telephone: +46 (0)370 33 28 00
Internet: www.garo.se

UK Address: Unit 16, Urban Express Park, Aston Hall Rd, Birmingham B6 7FH

Agent of equipment/Materiellslag: Electric Charging Station for EV with Radio Equipment/Laddstation för elbil med tillhörande radio utrustning

Trade Mark/Varumärke: GARO

Type Designation/Typbeteckning: EPC... serie

We hereby declare under our sole responsibility that our product fulfils the requirements of following EC directives/

Vi intygar härmed under vårt ensamma ansvar att vår produkt uppfyller krav enligt följande EU direktiv:

- The Low Voltage Directive (LVD) 2014/35/EU / Lågspänningsdirektivet (LVD) 2014/35/EU.
- Electromagnetic compatibility (EMC) 2014/30/EU / Elektromagnetisk kompatibilitet (EMC) 2014/30/EU.
- Radio Equipment Directive 2014/53/EU (RED) / Radiodirektivet (RED) 2014/53/EU.
- RoHS Directive (RoHS) 2011/65/EU / RoHS direktivet (RoHS) 2011/65/EU.
- The Electrical Equipment Safety Regulations 2016/UK / 2016 No 1101
- The Electromagnetic Compatibility Regulations 2016/UK / 2016 No 1091
- The Restriction of the Use of Hazardous Substances in Electrical and Electronic Equipment Regulations 2012/UK / 2012 No 3032

The following harmonised standards (latest edition) or technical specifications which comply with good engineering practice in safety matters in force within the EU/UK have been used in the design:/
Följande harmoniserade standarder (senaste utgåva) eller tekniska specifikationer som uppfyller god säkerhetsteknik-praxis inom EU/UK har använts i konstruktionen:

EN IEC 61851-1:2019
IEC/TS 61439-7:2020
EN 62311:2020
IEC 62955:2018
EN 60898-1
EN 61008-1

IEC 61851-21-2:2018 Other than residential environments
IEC 61000-6-3:2006/A1:2010
IEC 61000-6-2:2005
ETSI EN 301 489-17 V3.2.4
ETSI EN 301 489-52 V1.1.2
ETSI EN 301 489-1 V2.2.3
ETSI EN 301 489-3 V2.1.2

GARO AB
Company/Företag

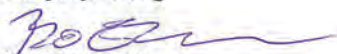
Sign/Underskrift

CTO
Position/Befattning

Bo Eriksson
Sign in printed letters/Namnförtydligande

Gnosjö 2023-03-25
Place Date/Ort Datum



Dokument/document		Utgåva datum/edition date
Försäkran om överensstämmelse/ Declaration of conformity		2023-04-13
Avdelning/department		
Produkt/Product		
Ansvarig/prepared	Version	Sida/page
Peter Magnusson	4	1 av/of 1

Manufacturer/Tillverkare: GARO AB
 Box 203
 S-335 25 GNOSJÖ
 Sweden
 Telephone: +46 (0)370 33 28 00
 Internet: www.garo.se

UK Address: Unit 16, Urban Express Park, Aston Hall Rd, Birmingham B6 7FH

Agent of equipment/Materielslag: Load Interface Unit Entity Balance / Effektenhet Entity Balance

Trade Mark/Varumärke: GARO

Type Designation/Typbeteckning: ELI... serie

We hereby declare under our sole responsibility that our product fulfils the requirements of following EC directives/

Vi intygar härmed under vårt ensamma ansvar att vår produkt uppfyller krav enligt följande EU direktiv:

- The Low Voltage Directive (LVD) 2014/35/EU / Lågspänningsdirektivet (LVD) 2014/35/EU.
- Electromagnetic compatibility (EMC) 2014/30/EU / Elektromagnetisk kompatibilitet (EMC) 2014/30/EU.
- Radio Equipment Directive 2014/53/EU (RED) / Radiodirektivet (RED) 2014/53/EU.
- RoHS Directive (RoHS) 2011/65/EU / RoHS direktivet (RoHS) 2011/65/EU.
- The Electrical Equipment Safety Regulations 2016/UK / 2016 No 1101
- The Electromagnetic Compatibility Regulations 2016/UK / 2016 No 1091
- The Restriction of the Use of Hazardous Substances in Electrical and Electronic Equipment Regulations 2012/UK / 2012 No 3032

The following harmonised standards (latest edition) or technical specifications which comply with good engineering practice in force within the EU/UK have been used in the design:/

Följande harmoniserade standarder (senaste utgåva) eller tekniska specifikationer som uppfyller god säkerhetsteknik praxis inom EU/UK har använts i konstruktionen:

- | | |
|-----------------------------|---------------------------------------|
| IEC/EN/UL/CSA 62368-1 | EN 61326-1:2013 |
| EN 61000-6-2:2005 | ETSI EN 301 489-17 V3.2.4 |
| EN 61000-4-6:2007 + A1:2011 | ETSI EN 301 489-1 V2.2.3 |
| EN 61000-3-2:2004 | EN 62311:2008 |
| EN 61000-3-3:2013 | ETSI EN 300328 v2.2.2 partial testing |

GARO AB
 Company/Företag

Gnosjö 2023-04-13
 Place Date/Ort Datum

 Sign/Underskrift

CTO
 Position/Befattning

Bo Eriksson
 Sign in printed letters/Namnförtydligande